



**PRODUCT CATALOG**  
**2021-22**



---

## OUR VISION

To be the finest skills - based total solution provider for turnkey projects, delighting our customers.



---

## OUR MISSION

The management team will focus on delivering great value to customers by developing high calibre professional skills in core competence and representing world-class instrumentation and automation products.



---

## OUR VALUES

- ⦿ Integrity and honesty
- ⦿ Passion for customers, for our partners and technology
- ⦿ Openness and respectfulness
- ⦿ Taking on big challenges
- ⦿ Constructive self-criticism, self- improvement and personal excellence
- ⦿ Accountability towards customers, partners and employees for commitments, results and quality



---

## OUR CORE COMPETENCIES

- ⦿ Project management
- ⦿ System integration and maintenance
- ⦿ Delivering the best solutions for MEP



# INDEX

## Binder

- Information	6
- Photo-Stability Chamber	7
- Growth Chamber	7
- Stability Chamber	8
- Ultra Low Temperature Freezers	8
- Convection Oven	9
- Vacuum Oven	9
- CO2 Incubators	10
- Microbiological Incubator	10
- Cooled Incubator(BOD)	10
- APT.Com Software	11

## Shimadzu

- Information	12
- Texture Analyzer	13
- Semi Micro Balances	14
- Analytical Balances	14
- Electronic Top Loading Balances	15
- Moisture Balances	16
- Accessories	17

## Novasina

- Information	18
- LabMaster Neo	19
- LabTouch	19
- LabSwift	19
- LabStart	19

## Interscience

- Information	20
- Lab blender	21
- DiluFlow Elite	21
- Manual colony counter	21
- Semi-automatic colony counter	22
- HD Automatic colony counter	22

## ANM Industries

- Information	23
- Circulating/Refrigerated Water Bath	24
- Sieve Shaker & Sieves	24
- Vacuum Oven	25
- Freezer Dryer	25
- Fixed & Variable Pipette	26
- Bottle Top Dispenser	26
- Ultrasonic Cleaner	26
- Personal Centrifuge	26
- High Speed Prog. Micro Centrifuge	27
- Refrigerated High Speed Micro Centrifuge	27
- Clinical / Doctor Centrifuge	27

- Vortex Mixers	28
- Micro Plate Mixers	28
- Overhead Stirrer	28
- Hot Plate Magnetic Stirrer	29
- Multichannel Magnetic Stirrer	29
- Shaker & Rocker	29
- Rotator & Roller	30
- Karl Fischer Titrator	30
- Leak Tester Apparatus	30
- Tablet Density Tester	30
- Tablet Hardness Tester - Portable	31
- Tablet Hardness Tester - Basic	31
- Tablet Hardness Tester - Advanced	31
- Torque Tester for Bottle Caps	32
- Tablet Friability Tester	32
- Tablet Disintegrating Apparatus	32
- Saybolt Chromometer	33
- 'U' TubeViscometer	33
- Kinematic Viscosity Bath	33
- Flash Point Apparatus Digital (ABEL-COC-PMCC)	33
- H2O Stabilizer	34
- Universal Statistics Printer	34
- Data Logger	34

## Lancer

- Information	35
- Lancer Ultima 810LX	36
- Lancer 815LX/820LX	36
- Lancer 1300LX/1400LX/1400LXP	36
- Lancer 1600LXP	37
- Lancer 1800LXA	37
- Accessories/Consumables	37

## Nabertherm

- Information	38
- Muffle Furnace with Tmax 1100°C -1300°C	39
- Muffle Furnaces with Tmax 1400°C-1600°C	39
- Muffle Furnace with Tmax 1600°C-1800°C	39
- Tubular Furnace with Tmax 1100°C-1300°C	40
- Tubular Furnace with Tmax 1500°C	40
- Tubular Furnace with Tmax 1600°C-1800°C	40

## Hirayama

- Information	41
- Economical Vertical Autoclave	42
- Basic Autoclave	42
- Automatic Autoclave	42

## Gram

- Information	43
- BioCompact II - ATEX certified refrigerators and freezers	44
- BioBasic - ATEX certified refrigerators and freezers	44
- Compact - ATEX certified refrigerators and freezers	44

## Bscience

- Information	43
- Industrial Refrigerators	45
- Industrial Freezers	45

## Lamy Rheology

- Information	46
- B-One Plus	47
- B-One Plus KU	47
- First Plus	48
- First Prodig	48
- First Prodig CP1000	49
- RM 100 CP 1000+	49
- RM 100 CP 2000+	50
- RheoTex	50
- TX 700	51
- MS-SV	52
- MS-ULV	52
- Thermocell	52
- CPS	53
- HeliPRO	53
- MS-CP	53
- Portable B-one	54
- Portable RM-100	54
- RM 100i	54
- RM 100L	54

## Amkette Analytics

- Information	55
---------------	----

## SRS

- Melting Point Apparatus - Automated	56
---------------------------------------	----

## Cyberlab

- 9mm Screw Top Vials, Cap and Septa	57
- 8mm Screw Top Vials, Cap and Septa	57
- 11mm Snap Top Vials, Cap and Septa	57
- 11mm Crimp Top Vials, Cap and Septa	57
- 9mm LC Clean Bonded Screw Cap	57
- 9mm Magnetic Screw Cap	57
- Ultra Mass Spec Certified Screw, Cap with Septa (Um4)	57
- 20ml HeadSpace screw type vial, Cap and Septa	58
- 20ml Headspace Vials, Cap and Septa	58
- 18mm PolyMag Screw Cap with SPME MicroCenter Septa	58
- EPA Kit	58
- Smart Septa (RFID)	59
- 1ml Clear Glass Shell Vial with PE Plug Cap	59
- 1ml PP Shell Vial with PE Plug Cap	59
- Manual Decapper 11mm	59
- Manual Crimper 20mm	59
- D2 Lamp	59
- Portable Electronic Balances	59

## ANMT- Scale

- Q7 Series Benchtop Scales	60
- QHW Series Benchtop Scales	60
- S29 Series Waterproof Scales	60
- BWS Waterproof Platform Scales	61
- BW Series Platform Scales	61
- KW Series Platform Scales	61

## HSI

- Powersonic 600 Series	62
-------------------------	----

## Polyscience

- Temperature Control Solutions (Water Baths)	62
---	----

## WS Tyler

- RO - Tap Test Sieve Shaker	62
------------------------------	----



# PRODUCT LISTING

<b>Autoclave</b>	<b>41/42</b>	<b>Furnaces</b>	
		- Muffle Furnace	<b>39</b>
<b>Balances</b>		- Tube Furnace	<b>40</b>
- Analytical Balances	<b>14</b>	<b>Moisture Analyzer</b>	
- Basic Top-loading Balances	<b>15</b>	- K F Titrator <sub>(alternate)</sub>	<b>30</b>
- Electronic Balances	<b>15</b>	- Moisture Balance	<b>16</b>
- Electronic Printer	<b>17</b>	- Water Activity Meter	<b>19</b>
- Moisture Balance	<b>16</b>		
- Specific Gravity Analyzer	<b>17</b>	<b>Ovens</b>	
- Static Remover (Ionizer)	<b>17</b>	- Heating and Drying Ovens	<b>09</b>
<b>Centrifuges</b>		- Vacuum Ovens	<b>09</b>
- Clinical/Doctor Centrifuge	<b>27</b>	- Software 21 CFR Part 11	<b>11</b>
- High Speed Programmable Micro Centrifuge	<b>27</b>		
- Refrigerated High Speed Micro Centrifuge	<b>27</b>	<b>Petroleum Test Instruments</b>	
- Personal Centrifuge	<b>26</b>	- Flash Point Apparatus	<b>33</b>
<b>Chromatography Consumables</b>		- Kinematic Viscosity Bath	<b>33</b>
- Vials, Cap & Septa	<b>57/58/59</b>	- Saybolt Chromometer	<b>33</b>
<b>Climatic Chamber</b>		- 'U' TubeViscometer	<b>33</b>
- Growth Chamber	<b>07</b>	<b>Rheometer</b>	<b>49</b>
- Photo-Stability Chamber	<b>07</b>	<b>Sieve Shaker &amp; Sieves</b>	<b>24</b>
- Stability Chamber	<b>08</b>	<b>Sonicator</b>	
- Software 21 CFR Part 11	<b>11</b>	- Ultrasonic Cleaner	<b>26</b>
<b>Cold Storage</b>		<b>Texture Analyzer</b>	<b>13</b>
- Freezers & Refrigerators	<b>44</b>	<b>Viscometer</b>	
- Industrial Refrigerators & Deep Freezers	<b>45</b>	- Viscometer	<b>47/48</b>
- Ultralow Temperature Freezers	<b>08</b>	- U Tube Viscometer	<b>33</b>
- Software 21 CFR Part 11	<b>11</b>	<b>Water Activity Meter</b>	<b>19</b>
<b>Freezer Dryer</b>	<b>25</b>	<b>Water Bath</b>	
<b>Glassware Washer-Dryer</b>	<b>36/37</b>	- Circulating/Refrigerated, Water Bath	<b>24</b>
<b>Incubators</b>		- Temperature Control Solutions	<b>62</b>
- Cooled Incubators	<b>10</b>		
- Co <sub>2</sub> Incubator	<b>10</b>		
- Microbiological Incubators	<b>10</b>		
- Software 21 CFR Part 11	<b>11</b>		
<b>Laboratory Instruments</b>			
- Fixed & Variable Pipette	<b>26</b>		
- Hot Plate Magnetic Stirrer	<b>29</b>		
- Melting Point Apparatus	<b>56</b>		
- Micro Plate Mixers	<b>28</b>		
- Multichannel Magnetic Stirrer	<b>29</b>		
- Rotator & Roller	<b>30</b>		
- Shaker & Rocker	<b>29</b>		
- Vortex Mixers	<b>28</b>		

BINDER's core purpose is to make a significant technical contribution to improving the health and safety of mankind. BINDER aims to provide customers with products that best support their daily laboratory work and allow them to continuously improve results.

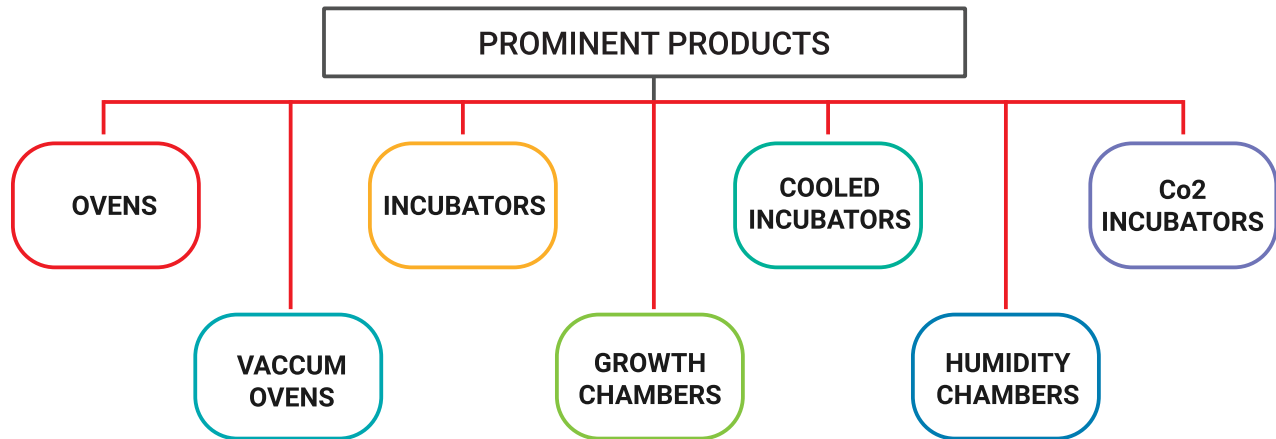

## TECHNOLOGICAL EDGE

### - **APT.Line Technology**

Binder's patented heating system 'APT.line' ensures homogeneous heating distribution in the inner chamber which in turn provides consistent results for any application.

### - **DCT Technology**

Binder's patented cooling system 'DCT' has constant directed airflow which ensures even distribution and prevents samples drying out during testing applications.

### - **Humidification Technology**

Binder Products have Permadyry and Steam production, two unique humidification processes, which allow stable adjustments and highest convenience when used.

## REAL WORLD APPLICATIONS

### - **Chemical Industry**

Safety chambers can easily handle solvent testing as they provide consistent dry conditions along with ISO 3215 compliance making them an ideal fit for painted surfaces.

### - **Automobile Industry**

Stability chambers from Binder are a great way to carry out car windshield testing in order to gauge the strength and durability under varied conditions.

### - **Research and Development**

Incubators with adherence to temperature, CO<sub>2</sub>, and O<sub>2</sub> levels assure optimum growth environments for live cultures.



## Photo-Stability Chamber

Equipped with ICH-compliant (Q1B) light source the variable position illumination cassettes in the photo-stability chamber offers homogenous lighting conditions.



- ◆ Humidity regulation with capacitive humidity sensor & vapor humidification.
- ◆ Patented APT.line pre-heating chamber technology.
- ◆ Positional illumination cassettes with ICH-compliant UV light source.
- ◆ Independent light dose control of UV-A & visible light with spherical sensor.



Food Testing



Pharmaceutical Testing as per ICH Q1B Guideline

## Growth Chamber

The precise regulation of the parameters light, temperature and humidity makes reproducible growth conditions, which can be achieved with great accuracy by Binder Growth Chambers.



- ◆ Reproducible growth conditions.
- ◆ Optional Arabidopsis and growth lamps.
- ◆ Patented APT.line pre-heating chamber technology.
- ◆ Positionable illumination cassettes, each with 5 fluorescent tubes.
- ◆ Active humidification and dehumidification system.



Ideal Growth Condition for Plant



Plant Tissue Culture

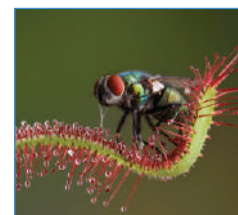

Insect Research



## Stability Chamber

With extended temperature/humidity ranges and precise maintenance of constant climate, these chambers provide incomparable reliability for stability.



- ◆ Constant test conditions across the entire usable space.
- ◆ Active humidification and dehumidification system.
- ◆ Patented APT.line pre-heating chamber technology.
- ◆ Accurate temperature control.
- ◆ Stability testing as per ICH guideline Q1A.



Pharmaceutical Packaging



Cosmetic



Drug Stability Test

## Ultralow Temperature Freezer

Ultralow temperature freezers ensure safe storage of samples for long time from few weeks to many years. Highly energy efficient with the use of environment friendly refrigerants and user friendly concept.

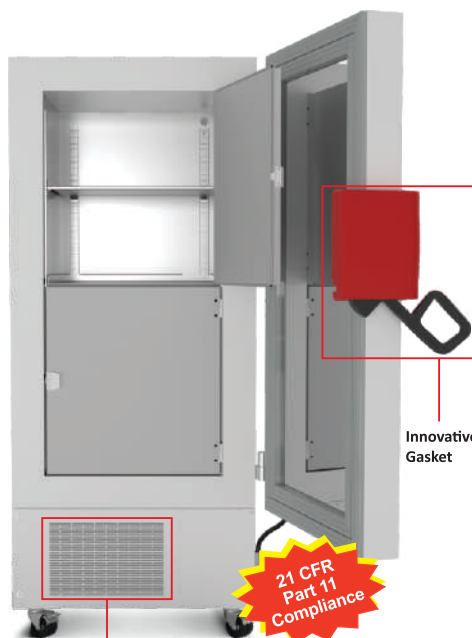

Innovative Door Gasket

21 CFR Part 11 Compliance

Powerful Compressor Cooling

- ◆ Temperature range: -40°C to -86°C.
- ◆ Lowest energy consumption.
- ◆ Environmental friendly refrigerants R-290 and R-170.
- ◆ Powerful cascade compressor cooling unit.
- ◆ Lowest ice buildup with innovative door gasket.



Uniform Growth Condition

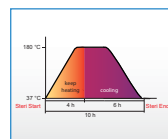

Minimum Risk of Contamination

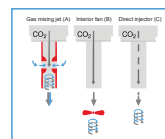

Stable pH Value



Cell Culture





## Convection Oven

The convection oven provides a highly efficient environment for all thermal processes including sterilization with fast and uniform drying.



- ◆ Optimal heating and drying up to maximum 300°C.
- ◆ Patented APT.line pre-heating chamber technology for homogenous temperature distribution.
- ◆ Class 2 integrated independent adjustable temperature safety device (DIN 12880).
- ◆ Adjustable fan speed and exhaust air flap.
- ◆ Adjustable ramp functions via program editor.
- ◆ Racks with anti-tilt protection for loading and unloading of samples.
- ◆ Minimum heat dissipation.

## Vacuum Oven

The vacuum oven gently dries combustible items with homogenous temperature distribution and with patented shelf-technology ensures optimal heat transfer.



- ◆ Uniform flow throughout the interior thanks to the Cross-Flow technology.
- ◆ Shatterproof, spring mounted safety glass panel.
- ◆ ATEX compliant explosion proof interior.
- ◆ Patented expansion racks technology for homogenous distribution of temperature.
- ◆ Low heat dissipation due to 60mm insulation.



**Homogeneous Temperature Distribution**



**Extremely Robust And Long-lasting Quality**



**Flexible, Mixed Stacking Options**



## Co2 Incubator

Valuable cell cultures need valuable CO2 incubators. The CO2 incubators are perfect for routine cell applications. Drift free CO2 sensor technology ensures stable pH values.



- ♦ Hot air sterilization at 180°C.
- ♦ CO<sub>2</sub> gas mixing with Venturi effect.
- ♦ Condensation protection with advanced humidification system.



**Uniform Growth Condition**

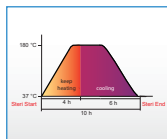

**Minimum Risk of Contamination**

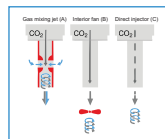

**Stable pH Value**

## Microbiological Incubator

Incubators for stable incubation conditions and reproducible results. The disinfection routine at 100°C minimizes the risk of contamination.



- ♦ Patented APT.line pre-heating chamber technology.
- ♦ Class 3.1 independent temperature safety device (DIN 12880) with visual temperature alarm system.
- ♦ Short temperature recovery times.
- ♦ Heat transfer through forced and gravity connection to suit individual requirements.

## Cooled Incubator (BOD)

Cooling Incubators with compressor technology and thermoelectric cooling combine performance and energy-efficiency for versatility.



- ♦ Cooling with Peltier and powerful compressor cooling.
- ♦ Disinfection possible at 100°C.
- ♦ Low vibration and environmental friendly Peltier technology incubators.
- ♦ Long term operational stability.
- ♦ Inner door made of tempered safety glass.



**Homogeneous Temperature Distribution**



**Easy Decontamination**



**Extremely Robust And Long-lasting Quality**



**Flexible, Mixed Stacking Options**



## APT.Com Software

Multi Management Software provides management, recording, programming, control, and documentation options, and much more.

- ♦ Graphically or entering the values manually
- ♦ Upto 100 units can be connected



Selection	AMC Address	IP Address	ESM Part	Manufacturer	Device Name	Device Type
<input type="checkbox"/>	8000000000000000	192.168.1.100				
<input type="checkbox"/>	8000000000000000	192.168.1.101				
<input type="checkbox"/>	8000000000000000	192.168.1.102				
<input type="checkbox"/>	8000000000000000	192.168.1.103				
<input type="checkbox"/>	8000000000000000	192.168.1.104				
<input type="checkbox"/>	8000000000000000	192.168.1.105				
<input type="checkbox"/>	8000000000000000	192.168.1.106				
<input type="checkbox"/>	8000000000000000	192.168.1.107				
<input type="checkbox"/>	8000000000000000	192.168.1.108				
<input type="checkbox"/>	8000000000000000	192.168.1.109				
<input type="checkbox"/>	8000000000000000	192.168.1.110				
<input type="checkbox"/>	8000000000000000	192.168.1.111				
<input type="checkbox"/>	8000000000000000	192.168.1.112				
<input type="checkbox"/>	8000000000000000	192.168.1.113				
<input type="checkbox"/>	8000000000000000	192.168.1.114				
<input type="checkbox"/>	8000000000000000	192.168.1.115				
<input type="checkbox"/>	8000000000000000	192.168.1.116				
<input type="checkbox"/>	8000000000000000	192.168.1.117				
<input type="checkbox"/>	8000000000000000	192.168.1.118				
<input type="checkbox"/>	8000000000000000	192.168.1.119				
<input type="checkbox"/>	8000000000000000	192.168.1.120				
<input type="checkbox"/>	8000000000000000	192.168.1.121				
<input type="checkbox"/>	8000000000000000	192.168.1.122				
<input type="checkbox"/>	8000000000000000	192.168.1.123				
<input type="checkbox"/>	8000000000000000	192.168.1.124				
<input type="checkbox"/>	8000000000000000	192.168.1.125				
<input type="checkbox"/>	8000000000000000	192.168.1.126				
<input type="checkbox"/>	8000000000000000	192.168.1.127				
<input type="checkbox"/>	8000000000000000	192.168.1.128				
<input type="checkbox"/>	8000000000000000	192.168.1.129				
<input type="checkbox"/>	8000000000000000	192.168.1.130				
<input type="checkbox"/>	8000000000000000	192.168.1.131				
<input type="checkbox"/>	8000000000000000	192.168.1.132				
<input type="checkbox"/>	8000000000000000	192.168.1.133				
<input type="checkbox"/>	8000000000000000	192.168.1.134				
<input type="checkbox"/>	8000000000000000	192.168.1.135				
<input type="checkbox"/>	8000000000000000	192.168.1.136				
<input type="checkbox"/>	8000000000000000	192.168.1.137				
<input type="checkbox"/>	8000000000000000	192.168.1.138				
<input type="checkbox"/>	8000000000000000	192.168.1.139				
<input type="checkbox"/>	8000000000000000	192.168.1.140				

Quick and Easy Unit Setup

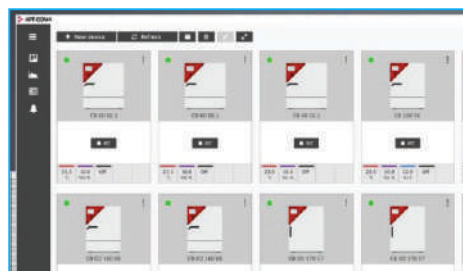

Unit Overview and Control at a Glance



Room Plan Can Be Created Via Drag & Drop

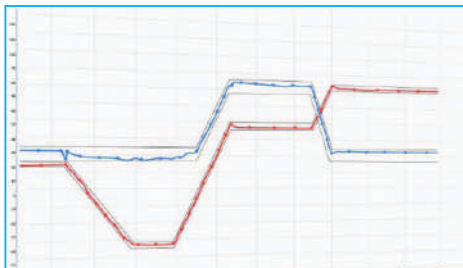

Diverse Presentation of Measured Data

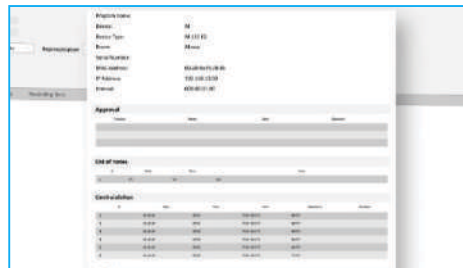

Data Export and GLP-compliant Data Retention

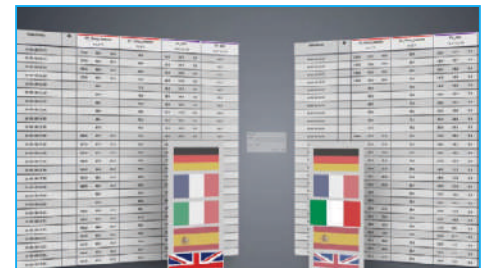

Multilingual Use



Shimadzu has been at the forefront of providing precise and quality solutions for the most challenging R&D, QA, and QC requirements for 100 years. Customer focused commitment and unwavering attention to technical excellence are two hallmarks of their history that guide them into the future.

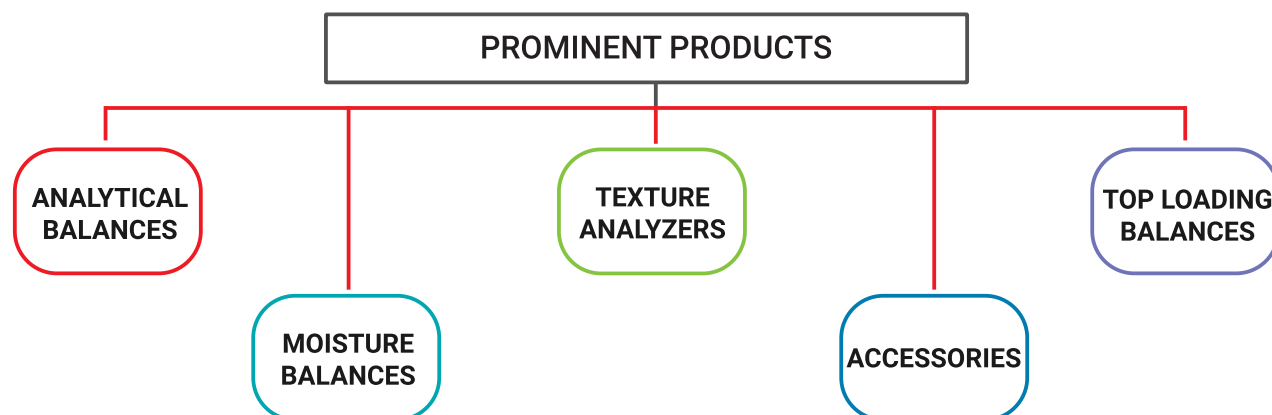

### TECHNOLOGICAL EDGE

#### - **Unibloc Technology**

UniBloc's compact, uniform structure ensures stable temperature characteristics, excellent response time and stable corner-load performance.

#### - **Labsolutions Software**

Integrates Data acquired from Balances to Analytical Network Data System Compliant with ER/ES Regulations.

### REAL WORLD APPLICATIONS

#### - **Pharmaceuticals**

- Weighing raw materials.
- Measure Moisture ratio and control the quality of raw materials.
- Measure drugs during drug manufacturing.
- Piece counting of tablets and capsules.

#### - **Chemical**

- Weigh Liquids and powders in R&D department.
- Measure specific gravity and moisture ratio of resin pellets, rubber, etc.
- Measure mass and moisture of dyes, pigments and inks.
- Control moisture ratio levels during catalyst production.

#### - **Metals/Precious Metals**

- Count the number of products which are very small in size.
- Check the weight of coated steel sheets/plates after polishing.
- Control moisture ratio and specific gravity of iron and steel raw material

#### - **Paints/Resins**

- Used for weighing raw materials and liquids.





## Texture Analyzer

Shimadzu presents the more convenient to use Next Generation Stand-Alone High Precision Table Top Type Texture Analyzer/UTM for the testing of materials. It brings exciting new dimension of quick, efficient testing to busy labs that need to improve productivity while maintaining quality.

EZ Test series comes with greater easy of operation through stand-alone or control by PC/Trapezium X Software, higher precision & accuracy of Interchangeable load cells from 1N/100g - 5kN/500kg, longer travel distance from 500mm - 920mm, ultra-high speed testing of 0.001-2000mm/min & 1500/3000mm/min return speed, automatic load calibration, accessible controls and comprehensive safety.



- ◆ Light weight and compact design.
- ◆ Single column, Finger-tip operation.
- ◆ Max capacity 500N & 5kN model.
- ◆ Travel upto 920mm.
- ◆ Fast return speed.
- ◆ Wide speed range 0.001 to 2000mm/min.
- ◆ Automatic load calibration.
- ◆ Crosshead speed accuracy  $\pm 0.1\%$ .
- ◆ High speed sampling of 1msec.
- ◆ Standalone operation without PC.
- ◆ USB interface for PC/Laptop.
- ◆ Touch load alarm.
- ◆ High precision load cell  $\pm 0.5\%$  of indicated value within 1/500 ~ 1/1 of indicated force.



Packaging



Food Texture



Plastics



Pharmaceuticals



Range of Jigs



Easy Control

### A wealth of specialized jigs suitable for Product Test in Diverse Fields

Physical evaluation testing is now required in more fields than ever before. EZ Test offers an ample selection of specialized jigs and features to support a wide variety of customer requirements with special jigs and applications for a number of fields, including foods, pharmaceuticals, medical devices, cosmetics, house hold items, packaging, automotive, electrical machinery & electronics, and rubber & plastics, etc.

### TRAPEZIUM X – Cutting Edge Software for Testing Machines

Trapezium X provides a state of the art user interface, comprehensive functions and easy to use design to improve the efficiency of your testing.



### TRAPEZIUM X – Cutting Edge Software for Testing Machines

Trapezium X software is ideal for measuring the texture of foods, evaluating various quality parameters, or measuring the physical properties of pharmaceuticals, cosmetics, and other specimens. It allows creation of user-defined control patterns that enable creation of data processing parameters specialized for foods, such as hardness, brittleness, and energy.

Compression tests (piercing, penetration, and break analysis tests), tensile tests, texture tests (two-bite method), indentation tests, gel strength. tests, shear/cutting tests, adhesiveness tests, hardness tests, and more.



## Semi-Micro & Analytical Balance

### APW-D SERIES

Advanced Performance UniBloc Semi-micro Balances and provides High-Speed Response and Stability. Available in super range and dual range.



- ◆ Capacity range: 52g to 220g.
- ◆ Readability: 0.01mg.
- ◆ 21 CFR Part 11 Compliant.
- ◆ Variety of Accessories suitable for semi-micro measurements.
- ◆ Buffer Solution and Sample Preparation modes for HPLC Users(only in APW Series Model).
- ◆ RS-232C Interface.
- ◆ User ID and Password Management.
- ◆ Minimum Measurement Value (only in APW Series Model).
- ◆ Periodic Inspection Support Function (only in APW Series Model).

### AP SERIES

Advanced Performance UniBloc Balances and provides High-Speed Response and Stability.



- ◆ Capacity range: 120g to 320g.
- ◆ Readability: 0.1mg.
- ◆ 21 CFR Part 11 Compliant.
- ◆ Variety of Accessories and options suitable for analytical measurements.
- ◆ Buffer Solution and Sample Preparation modes for HPLC Users(only in APW Series Model).
- ◆ RS-232C Interface.
- ◆ User ID and Password Management.
- ◆ Minimum Measurement Value (only in APW Series Model).
- ◆ Periodic Inspection Support Function (only in APW Series Model).

### AT-R SERIES

Basic Model with Improved Convenience.



- ◆ Capacity range: 64g to 320g.
- ◆ Readability: 0.1mg.
- ◆ Easy settings enable responsiveness and stability to be freely changed.
- ◆ Basic Analytical balance equipped with 2 interfaces: USB and RS232C.
- ◆ Prevent Human error by direct transfer of weight values to the computer.
- ◆ AT-R Series balances have been shown to operate with PLCs from major companies.
- ◆ Addition of ionizer increases measurement reliability.



## Electronic Top Loading Balance

### UP SERIES

Superior Response Significantly Increases Weighing Efficiency.



- ◆ Capacity range: 220g to 8.2kg.
- ◆ Readability: 0.0001g, 0.01g and 0.1g.
- ◆ Significantly improved response time of approximately 1 second provides fastest response performance in its class.
- ◆ Full Aluminum Die Cast Housing Provides Excellent Chemical Resistance.
- ◆ Balance Keys Weighing Data Collection Software.
- ◆ Using the highly impact-resistant UniBloc sensor minimizes downtime due to malfunctions.
- ◆ UP Series balances have been shown to operate with PLCs from major companies.
- ◆ Addition of ionizer increases measurement reliability.

### TW/TX/TXB SERIES

Extremely capable and easy to operate.



- ◆ Capacity range: 220g to 6.2kg.
- ◆ Readability: 0.001g, 0.0002g, 0.01g, 0.1g, 1g.
- ◆ PSC, Perfect Self Calibration.
- ◆ Automatic touch-key calibration.
- ◆ Clock calibration.
- ◆ GLP/GMP/ISO calibration report.
- ◆ Piece counting function.
- ◆ Specific gravity measurement.
- ◆ Backlight LCD.
- ◆ Checkweighing.

### BL SERIES

High-resolution balances made affordable.



- ◆ Capacity range: 220g to 3.2kg.
- ◆ Readability: 0.001g, 0.01g, 0.1g.
- ◆ Piece counting function.
- ◆ Analog bar graph display.
- ◆ Change among many weighing units and functions with a single touch.
- ◆ Carat Measurement.
- ◆ Data Transfer Port.
- ◆ Equipped with a Square Pan for Ease of Operation.



## Moisture Balance

### MOC63U

Makes moisture content measurements quick and easy.



- ◆ Next-Generation Mass Sensor: UniBloc.
- ◆ Windows Direct Function.
- ◆ Backlit LCD.
- ◆ RS-232C interface.
- ◆ USB Interface.
- ◆ In-Built Halogen Heater for moisture measurements.

**A Total of Five Modes Makes This Balance Compatible with a Variety of Sample Measurements**

#### Ending Modes

- ◆ Automatic/Timed Ending Mode.

#### Alternate Drying Modes

- ◆ Rapid/Slow/Step Drying Mode.

### MOC-120H

Measure the Moisture Ratio of even large or large amounts of sample.



- ◆ The moisture ratio is found by heating the sample with the built-in infrared heater.
- ◆ The sample pan measures 130 mm in diameter, which is optimal for large amounts of samples.
- ◆ Importing results to a PC is easy (equipped with the Windows Direct function).
- ◆ Equipped with the UniBloc aluminum block mass sensor.
- ◆ Next-Generation Mass Sensor: UniBloc.
- ◆ Windows Direct Function.
- ◆ Backlit LCD.
- ◆ RS-232C interface.





## Accessories

### Static Remover (Ionizer)



- ◆ Static charge on a sample or in the container can cause fluctuations in weight.
- ◆ Stablo-AP provides reliable measurement by removing static electricity.
- ◆ AC Corona discharge method for fast Ionization (1 Second typically).
- ◆ Can be used easily in handheld form, setting up on stand, or being fixed within a balance.
- ◆ An Excellent solution against static electricity.

## Electronic Printers

Enhanced support for ISO/GLP/GMP.



- ◆ Enhanced visibility for OLED Display.
- ◆ Includes functionality for preventing date alterations.
- ◆ Supports GLP/GMP using password protection- based date/time alteration prevention.
- ◆ Powered by Rechargeable Batteries.
- ◆ Status Display with Enhanced Visibility for OLED Display.

## Specific Gravity Analyzer

Measures a variety of gravity values with the Immersion Method.



- ◆ Capable of automatically calculating and displaying specific gravity values.
- ◆ Liquid density can also be measured by using an optional sinker.



Since its inception, for more than 50 years, Novasina AG, Switzerland is the Leader in the production of Water Activity measurement, offering reliable, high-quality “Swiss made” Products that perform accurately, quickly and with high reproducibility. Novasina also combines unique sensor technology and know-how in development and production of measurement instruments so that their customers can improve their quality management process and are in better control of parameters that affect their product.

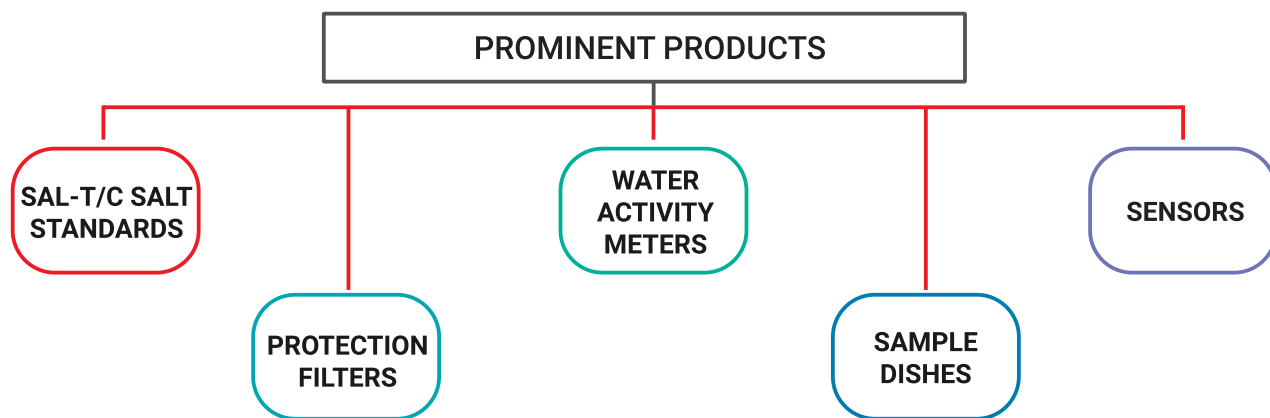

### TECHNOLOGICAL EDGE

- **Resistive Technology**

It makes use of change in electrical resistance due to humidity to give accurate, repeatable, and hysteresis free readings for a variety of samples in various physical states.

- **Compliance Provisions**

21CFR Compliant Software available in select Models, in addition to providing necessary functions which are required for HACCP (Hazard analysis and critical control points) compliance.

- **Reusable RFID-Tagged Calibration SAL-T Standards**

### REAL WORLD APPLICATIONS

- **Chemical Industry**

Water is the largest component in chemical compounding and gauging the quality using water activity meters assures consistent results.

- **Food Industry**

Water activity measurement by Novasina products helps realize the inherent risk of microbiological growth and maintain consistency of chocolate quality.

- **Pharmaceutical Industry**

Water migration between shell and filling of a soft or hard gelatin capsule causes quality issues in the product. Performing a water activity measurement provides you status of free water in your product and its impact on quality and stability of ingredients in the final product.



## LabMaster Neo

The LabMaster neo provides accurate and repeatable and accurate aW measurements and also supports in the investigation of the causes of product spoilage, texture changes or rancidity.



- ◆ Full temperature control ( 0-60°C ) for highest accuracy.
- ◆ Complete 21CFR11 compliance thanks to audit trail and user management.
- ◆ Various measurement modes incl. fast mode.
- ◆ Reusable SAL-T calibration standards with automatic recognition by RFID tag.
- ◆ Automatic equilibrium detection for best repeatability and comparability of measured values.

## LabTouch

The Lab Touch can measure aW for many samples, whether liquid, gel-like or solid and with its ergonomic design and touch screen, it makes water activity measurement easier than ever before.



- ◆ Fast mode for a measurement in max. 10 minutes.
- ◆ Semi-temperature controlled measurement chamber.
- ◆ SD card for easy measurement data management.
- ◆ Reusable SAL-T calibration standard.

## LabSwift

The Lab Swift is Suitable for products such as powder or dried fruit with low-medium aW values along with a rechargeable battery so the device can be placed anywhere.



- ◆ Battery option for local flexibility.
- ◆ SD card for easy measurement data management.
- ◆ Reusable SAL-T calibration standards.
- ◆ Fast device for medium aW measured value range.

## LabStart

The Lab Start allows water activity measurement with the unique Novasina technology of the resistive-electrolyte sensor with an economical budget.



- ◆ Reusable SAL-T calibration standards.
- ◆ Simple starter measuring device.
- ◆ Sturdy base plate, no tipping over.
- ◆ User-friendly design.



Interscience has been developing and manufacturing innovative scientific equipments since 40 years. The Company has become a Global reference as a manufacturer in the field of Microbiology with more than 30 patents filed worldwide. Its products guarantee safe and fast analyses for the food, pharmaceutical, cosmetics, environmental and medical research industries while providing excellent quality and great service on an international scale.

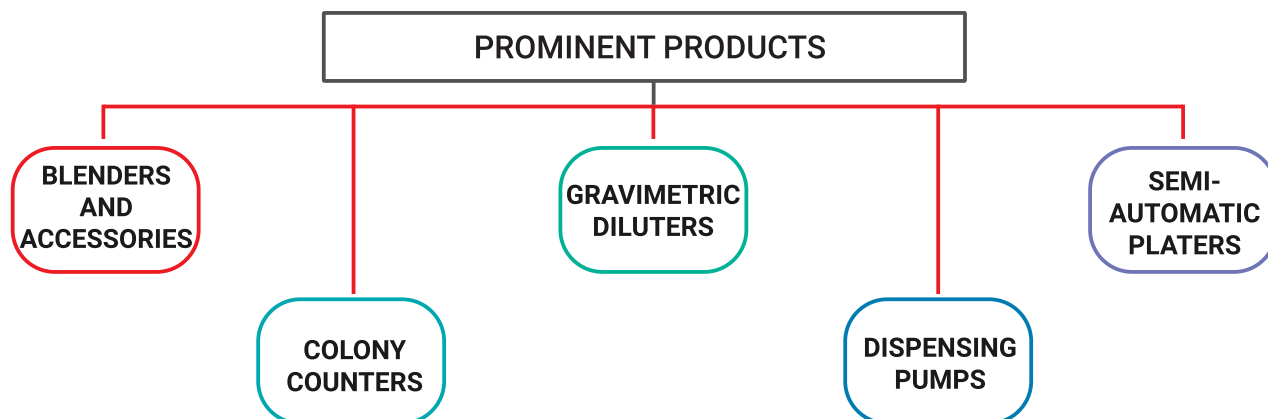

## TECHNOLOGICAL EDGE

### - GeckoGrip System

The revolutionary system ensures ultra-adhesive capability without any adhesive gums being used. This patented technology ensures hygienic sample hold.

### - Dark Field Technology

The light is diffused and the colony is perfectly lit on a dark background. As a result: the lighting is accurate and the contrast is optimal for counting.

## REAL WORLD APPLICATIONS

### - Pharmaceutical Industry

Interscience colony counters separate clustered colonies and then provide a count of the same using inhibition zone reading.

### - Food Industry

Blenders from Interscience allow a rapid and simple homogenizing of varied food samples providing convenience across a range of edible items.

### - Cosmetics

Skin care essential products require hygienic blending and sensitive colony testing to ensure its benefits last longer. Multiple products from Interscience help in such testing.





## Lab blender

BagMixer® is a highly efficient lab blender for solid sample preparation. With a blender bag, it guarantees optimal microbiological extraction in less than 60 seconds and eliminates all risks of cross contamination.



- ◆ Optimal bacterial extraction.
- ◆ Adjustable blending power.
- ◆ Click & Clean.
- ◆ Q-Tight closing.
- ◆ User-friendly.

## DiluFlow Elite

Along with semi-automatic dilution of a solid sample, DiluFlow® Elite is designed for its traceability features which enable the recording of all the operations. It is Programmable and connectable with up to 6 diluents.



- ◆ For pharmaceutical and cosmetics industries.
- ◆ Powder Mode.
- ◆ High accuracy.
- ◆ Connectivity and full traceability.
- ◆ Robotic arm and protective plate.
- ◆ Ultra-low profile.
- ◆ Removable drip tray.
- ◆ GeckoGrip holding system.
- ◆ LightCode.
- ◆ Magnetic BagOpen.
- ◆ Autotare Function.
- ◆ Multi-distribution mode.
- ◆ Up to 6 diluents.

## Manual colony counter

Scan® 100 is a manual colony counter equipped with a LED lighting system and an ergonomic hand rest. The Dark Field technology provides indirect, accurate and contrasted lighting of the colonies.



- ◆ Dark Field Technology.
- ◆ Touch surface with adjustable sensitivity.
- ◆ Great ergonomics.
- ◆ Data export via USB, LIMS, Excel™.
- ◆ Traceability.



## Semi-automatic colony counter

Scan® 300 is a semi-automatic colony counter with the essential features to start the automatic colony counting and is specifically designed for environments of food microbiology (PCA, VRBG, MRS...).



- ◆ Counting on pour, surface, Spiral, circle mode plated dishes.
- ◆ Accuracy and repeatability.
- ◆ 21 CFR Part 11 included.
- ◆ Traceability.
- ◆ Print of the results.
- ◆ Dark Field lighting technology.
- ◆ Ideal with dataLink full traceability system.

Scan® 500 is a semi-automatic color colony counter providing quick and efficient counting of the colonies on the most common supports. Scan® 500 guarantees an excellent reproducibility and the automatic saving of images and results.



- ◆ Counting on pour, surface, Spiral, circle mode plated Petri dishes.
- ◆ Counting on chromogenic agar.
- ◆ Accuracy and repeatability.
- ◆ 21 CFR Part 11 included.
- ◆ Traceability.
- ◆ Print of the results.
- ◆ Dark Field lighting technology.
- ◆ Ideal with dataLink full traceability system.

## HD Semi-Automatic colony counter

Scan® 1200 (HD semi-automatic colony counter) high resolution semi-automatic color colony counter, enables an adaptability to all media in labs and a great user comfort with high accuracy, an excellent reproducibility and semi-automatic saving of images and results.

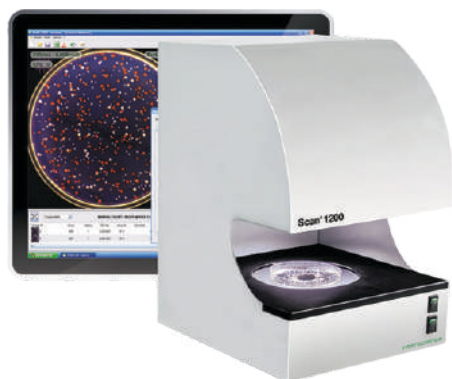

- ◆ Counting on pour, surface, Spiral, circle mode plated Petri dishes.
- ◆ Counting on chromogenic agar, PetriFilm™, MC-media Pads™, Compact Dry™, filtration membranes.
- ◆ Accuracy and repeatability.
- ◆ 21 CFR Part 11 included.
- ◆ Traceability.
- ◆ Print of the results.
- ◆ Dark Field lighting technology.
- ◆ Ideal with dataLink full traceability system.



ANM INDUSTRIES Pvt. Ltd is a company within ANM Alliance Group which is one of the largest companies in the laboratory instrument Business. Their products are under third party testing / design appraisal to achieve conformance with the international standards and criteria. They focus on delivering great value to customers by developing high caliber professional skill in core competence areas and representing world-class instrumentation and automation products.

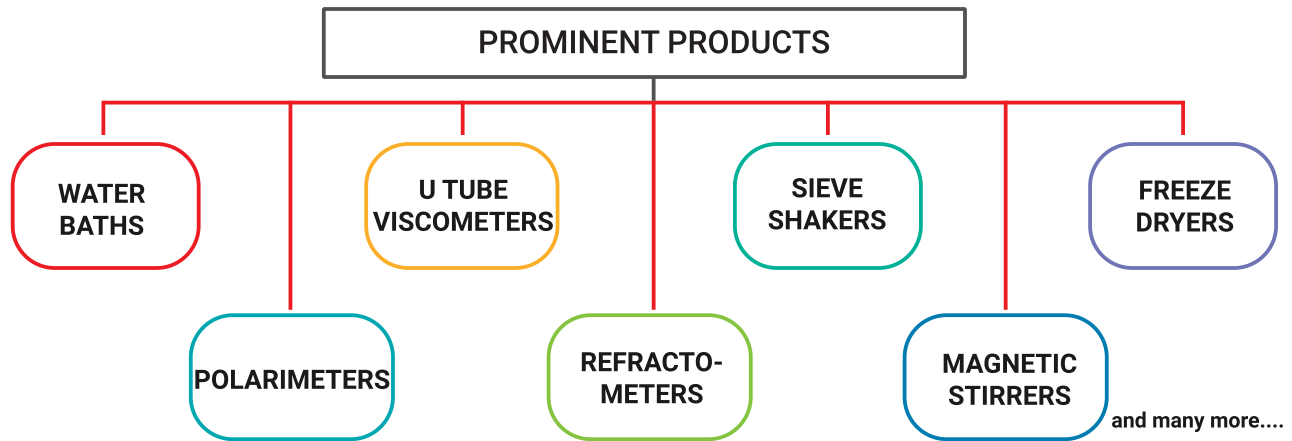

### TECHNOLOGICAL EDGE

**- Shelf Heating Technology**

With a Heater mounted below the tray, consistent heating is ensured along with rapid and equal distribution of the heat without any thermal loss. This in turn provides consistency and accuracy for various applications.

**- Software Availability**

With software driven control (for limited products), automated execution is possible, taking of a majority of human while ensuring optimum standards are maintained for routine tasks.

**- Improved User interface**

With provisions like touchscreen display, memory function, and USB port, the user is allowed to easily carry out project management, system integration/maintenance, and getting real solutions with the instruments provided.

### APPLICABLE INDUSTRIES

- |                           |                             |                          |
|---------------------------|-----------------------------|--------------------------|
| - Automobile Industry     | - Food/Beverage Industry    | - Environmental Research |
| - Chemical Industry       | - Paint & Coatings Industry | - Packaging Industry     |
| - Electronics Industry    | - Petroleum Industry        | - Transport Industry     |
| - Pharmaceutical Industry | - Hydrocarbon Industry      | - Construction Industry  |
| - Cosmetics Industry      | - Biotech Industry          | - Hospitality Industry   |
| - Aerospace Industry      | - Agricultural Industry     | - Healthcare Industry    |
| - Textile Industry        |                             |                          |



## Circulating/Refrigerated Water Bath

ANM Circulating water bath is designed for multiple application for cooling as well as heating along with circulation. With precise and accurate temperature control, and wide temperature range this general purpose unit uses in almost every laboratories.



- ◆ Various temperature range: (-10°C/ -20°C/-30°C/-40°C to 100 °C).
- ◆ Table Top Model.
- ◆ External Circulation.
- ◆ Used as chiller, circulator, water bath & refrigerated bath.
- ◆ Continuous Operation.

## Sieve Shaker & Sieves

The Electromagnetic Sieve shaker is a solid state instrument designed to assess the particle size distribution of a granular material. Due to non-rotating parts the operation is quick and maintenance free.



- ◆ 3 directional shifting motion.
- ◆ Intermittent and Continuous tapping motion.
- ◆ Very low noise operation.
- ◆ Sieves made from SS 316 with laser marking of specification & serial number.
- ◆ Specially designed sieves without crevasses and without Lead.

### Test Sieves



- ◆ Sieve Material (Mesh-316 / Ring-304).
- ◆ Mesh is uniformly tensioned & welded.
- ◆ No soldering process involved.
- ◆ Lead free which makes it ideal for food grade products.
- ◆ Calibration certificate - optional.



## Vacuum Oven

The ANM VO-100 is used for drying of heat sensitive materials. It uses Shelf Heating Technology for rapid and equal heating throughout the plate without any thermal Loss.



- ◆ These units are fitted with highly accurate controller that allows gentle drying of heat sensitive materials & highly hygroscopic materials.
- ◆ The vacuum ovens can dry faster than the conventional ovens & avoid damage due to rapid temperature overshooting.
- ◆ They come with a separate vacuum release valve to release the vacuum by gentle turn of the knob. An air release inlet is located below the tray to avoid sample disturbance due to air blowing.
- ◆ Heater mounted below the tray, ensures rapid and equal heating without any thermal loss.
- ◆ The interior and the exterior of the chamber is made of SS 304 with one aluminum rack.

## Freezer Dryer

Freeze dryer is widely used in medicine, pharmacy, biology research, chemical industry and food production, etc. After freeze drying process, a long term preservation for material is much easier.

The vacuum freeze drying technology, which is also called sublimation drying, is a technical method that freezes the samples in advance, and then sublimates its moisture under vacuum state.



- ◆ Condenser, trays, drying shelf and pre-freezing shelf are made of stainless steel 304, anti-corrosion.
- ◆ Color LCD touch screen display.
- ◆ Condenser with uniform and good ice capture function.
- ◆ Transparent acrylic drying chamber.
- ◆ Vacuum pump with high pumping speed, to reach good final vacuum.
- ◆ CFC-free refrigerant, low noise, good efficiency.
- ◆ With USB port to output freeze drying data.





## Fixed & Variable Pipette

Large range of Pipettes in fixed and variable volume range comes with high accurate and calibration certificates. These pipettes are fully autoclave-able and easy to calibrate and service the pipettes.



- ◆ Ergonomic design ensuring light weight and soft plunger movement.
- ◆ Smart engineering design.
- ◆ Click-stop digital system for volume setting.
- ◆ 100% Fully Autoclavable Pipettes.
- ◆ Color coded for easy identification.
- ◆ Calibration conforms to DIN 12650 & EN ISO 8655 standards.

## Bottle Top Dispenser

The ANM BTDs are economical wiping seal dispenser designed to handle many of the fluids used in every laboratories. The easy attachments for all the standard bottles enables the easy, safe and accurate dispensing of the fluids. BTDs come with various variable volume size and are fully autoclave-able.



- ◆ Excellent chemical resistance.
- ◆ Four ranges of bottle-top dispensers cover a volume range from 0.5ml to 50ml.
- ◆ Easy to clean and maintain.
- ◆ The optional flexible discharge tube with safety handle permits fast and precise dispensing.

## Ultrasonic Cleaner

With advanced MOSFET technology in generation of Ultrasonic waves are very efficient. The Ultrasonic cleaner with various operation modes like degassing, Cleaning, Sweep modes gives optimum uses of the Sonicator in its application.



- ◆ Powerful and reliable cleaning.
- ◆ Built-in micro processor controller with MOSFET based technology.
- ◆ Built-in digital thermometer and timer to set an optimum condition for cleaning.
- ◆ Easy to read operation status on digital display.

## Personal Centrifuge

The compact and handy centrifuge made from highest quality material and components will fit seamlessly and deliver exceptional and optimum performance. The specially designed centrifuge provides enhanced airflow to prevent the rise of temperature inside the unit.



- ◆ 8 place closed rotor for better airflow, better efficiency and low heat generation.
- ◆ Electronic brake for immediate stop on lid opening for user safety.
- ◆ Digital display of time and RPM.
- ◆ Microprocessor controlled centrifuge with variable speed and time setting, along with last run memory function.
- ◆ Imbalance detection with auto cut off.



## High Speed Programmable Micro Centrifuge

The programmable micro centrifuge U 15000 P comes with a powerful brushless DC motor and enhanced air flow design to protect sensitive samples from rising temperatures. More over features like imbalance detection, lid-lock safety and one touch operation make it extremely convenient to use the instrument.



- ◆ Intuitive simple interface for quick and convenient setting.
- ◆ Lid lock safety - Lid opens automatically on run completion.
- ◆ One touch Short Spin operation & RPM / RCF conversion.
- ◆ Small footprint saves valuable bench space.
- ◆ Suitable for use in hoods or cold rooms.
- ◆ Compatible with Mini Hematocrit Rotor & PCR strip rotor.
- ◆ Brushless DC Motor - Maintenance free, Delivers Better Power/Weight Ratio & Fit for extended runs.
- ◆ Microprocessor controlled centrifuge with variable speed and time setting, along with last run memory function.

## Refrigerated High Speed Micro Centrifuge

This product is a multipurpose versatile laboratory centrifuge which caters to all your centrifugation requirements. It has a user-programmable interface, automatic internal diagnosis output, and emergency lid release to ensure exceptional functionality and Maximum safety.



- ◆ Adjustable speed range from 500 to 15000 RPM.
- ◆ Temperature range from -20°C to 40°C.
- ◆ Electronic Imbalance detection.
- ◆ Stainless Steel Rotor Chamber.
- ◆ Lid Lock Safety.
- ◆ One touch toggling (Between RCF and RPM).
- ◆ 4 Rotor Options.

## Clinical / Doctor Centrifuge

The Doctor or Clinical centrifuge is designed to create the maximum user- satisfaction and takes safety to next level by incorporating various failsafe features and optimum use in clinical application.



- ◆ 15ml tubes x 6 place, fixed angle Rotor.
- ◆ Autoclavable Rotor.
- ◆ Speed Range: 500 to 6500 RPM (2000xg RCF).
- ◆ Automatic Imbalance detection , Safe operation.
- ◆ Ideal for a clinical lab.



## Vortex Mixers

The Digital Vortex equipped with high power Brushless DC motor which can deliver speed up to 4200 RPM. The orbital diameter is 4 mm and user can set speed from 300 RPM to 4200 RPM for gentle to rigorous mixing.



- ◆ Touch and continuous operations.
- ◆ Wide speed range of 0-2800 RPM, stepless speed regulation.
- ◆ Used for various mixing applications with optional adapters, handles upto 48 tubes.
- ◆ Specially designed vacuum suction feet hold to the work surface and prevent the unit from movement.
- ◆ Aluminum cast base.

## Micro Plate Mixers

The ANM Micro-plate mixers are an essential instrument for mixing in individual micro plates of various kinds and this makes an ideal everyday lab instrument. These mixers have a footprint as little as the plate dimension itself and provides thorough mixing for the desired applications.



- ◆ Compact & universal Micro Plate Mixer suitable for small vessels & 96 micro plate.
- ◆ Wide range of accessories, easy installation and replacement.
- ◆ Continuous operation.
- ◆ Stepless speed regulation of motor.
- ◆ DC brushless motor, low running noise and long service.

## Overhead Stirrer

ANM Overhead Stirrers delivers exceptional flexibility to meet all stirring requirements. With compact form factor and powerful motor, these stirrers are built with safety features like over load, over temperature and over current conditions which provides excellent performance.



- ◆ High reliability, long continuous service, outstanding performance.
- ◆ Cover the speed range 50 to 2200 RPM.
- ◆ Accurate and controlled speed of stirrer.
- ◆ Brushless DC motor drive.
- ◆ Low noise and maintenance free.
- ◆ Set value and actual value can be displayed.
- ◆ Real-time monitoring torque and speed.
- ◆ Overload protection, motor would automatically stop in case of continuous overload.



## Hot Plate Magnetic Stirrer

The Hotplate magnetic stirrers through its unique features deliver exceptional performance under high loads with complete reliability and safety. It's State of the art technology guarantees peace of mind for an unmatched user experience in addition to having intelligent modes of operations.



- ◆ Magnetic stirrer suitable for unsupervised operation, with new stir technology..
- ◆ Automatic judgement stirring bar displacement and capture.
- ◆ Easy to read digital display.
- ◆ Fuzzy logic control & microprocessor technology guarantee max. control accuracy.
- ◆ Different heating modes ensure the stirring function does not change due to external factors.
- ◆ Individually controlled stirring for consistency with various samples. Stepless speed regulation.
- ◆ External rotor brushless motor reduces operating noises and increases motor.
- ◆ Electronic speed control motor provides constant speed during changes in load.

## Multichannel Magnetic Stirrer

The Multichannel Magnetic stirrers provide accurate and precise performance along with necessary safety features. The Heating efficiency and programing features provide explicit commands for better user experience



- ◆ No moving parts, truly maintenance free.
- ◆ Low aspect ratio (just 12 mm thick).
- ◆ Software driven gradual acceleration.
- ◆ Microprocessor controlled with last run memory feature.
- ◆ Pulse mode-reverses the direction every 30 seconds for proper mixing.
- ◆ Universal power supply-small wall mount adaptor.
- ◆ Corrosion resistant SS top surface to fight harsh chemicals.

## Shaker & Rocker

ANM Shakers are used to mix, blend, or to agitate substances in tube(s) or flask(s) by shaking them, which is mainly used in the fields of chemistry and biology. A shaker contains an oscillating board which is used to place the flasks, beakers, test tubes, etc. Platform shakers with shaking weight up to 15 kg having Orbital / Linear motion up to 70 mm.



- ◆ Fast, safe, reliable measurements.
- ◆ Built-in digital thermometer.
- ◆ Microprocessor controlled ramps.
- ◆ Ramp rates from 0.5 to 20 °C/min.
- ◆ Easy to clean and maintain.
- ◆ Tube tapper packs samples.
- ◆ Mercury free.
- ◆ Safety certified.





## Rotator & Roller

Highly efficient Tube Rollers ensures efficient mixing of blood samples, viscous substances and liquid-solid suspensions. With reliable and durable motor increases the performance in a compact package.

ANM Tube Rotators provides smooth and effective mixing which are ideal for biological samples particularly blood samples with maximum capacity of tubes. Easy to operate, remove and install attachments for replacement and cleaning makes it user friendly in every sense.



- ◆ Rotisserie rotating / Smooth rocking / Rocking and rolling motion.
- ◆ Used with a wide variety of accessories.
- ◆ Simultaneous LCD display for speed and timer adjustment.

## Karl Fischer Titrator

The Karl Fischer Titrator is used for determining the amount of water in any product during the manufacturing process with the assistance of conductometric detection method.



- ◆ Karl Fischer method uses coulometric or volumetric titration.
- ◆ The popularity of the Karl Fischer titration is due to several practical advantages that it holds over methods of moisture determination such as high accuracy, speed, selectivity and precision, typically within 1% of available water.
- ◆ The sample quantity required for analysis is small.
- ◆ Little or no sample preparation is needed.
- ◆ The analysis is typically complete within a minute.

## Leak Tester Apparatus

The advanced leak test apparatus is used to test the quality of packing process in strips, blisters and sachets containing tablets, granulates and liquids in various industries like food, pharmaceutical and chemical etc.



- ◆ Automatic Pressure correction.
- ◆ Self-Test, Graphical Display.
- ◆ Built in Mini Dot Matrix Printer.
- ◆ Data transfer to PC through LAN/RS 232 port/USB.
- ◆ High quality Pumps / Relays.
- ◆ Quick fit PU Tubing.
- ◆ 3 level Password.

## Tap Density Tester

The Tap density tester measures the tapped density of powders and granulates of flaked material by standardized procedures. The instrument uses advanced engineering techniques to get the enhanced accuracy and reproducibility.



- ◆ 20 X 4 line alphanumeric LCD display with backlit.
- ◆ Tap Density, Initial Density, Compressibility Index.
- ◆ Independent programmable setups for user & USP mode with storage.
- ◆ RS232 printer attachment facility.
- ◆ Automatically calculate result parameters like Hausner ratio.
- ◆ Automatically stores last result.
- ◆ Power failure detection facility.





## Tablet Hardness Tester - Portable

The very Handy, easy to operate and compact instrument with very high accuracy for the tablet hardness testing gives direct test results on the digital display with audio and visual alarms.



- ◆ High levels of accuracy with Peak force Measurements.
- ◆ Easy to operate and handy to carry.
- ◆ Force gauge display the test direction.
- ◆ Allows for real time data transfer.
- ◆ Can store 10 test values and calculate the average of the stored test value automatically.
- ◆ Zero point adjustment for calibration.

## Tablet Hardness Tester - Basic

The basic Hardness tester offers excellent flexibility and configurability in measuring thickness, diameter and hardness of a tablet. The robust design eliminates the need of a thickness gauge, it's redundant calibration and reducing over all cost.



- ◆ High Quality Electronic Load cell.
- ◆ 3 Parameter - Thickness, Diameter and Hardness up to 500 N.
- ◆ Easy Calibration and No Tilt During Calibration.
- ◆ +/- 0.06 mm accuracy.
- ◆ No extra gauges for thickness, all in one measurement.
- ◆ Built in Mini Dot Matrix Printer.
- ◆ Self-test and overload protection.
- ◆ No tablet detection.
- ◆ Password Protection with real time clock.

## Tablet Hardness Tester - Advanced

Measuring the Weight, Width, Thickness, Diameter and Hardness, the advanced tester is both USP and EP compliant and offers excellent flexibility and configurability. The design removes the use of thickness gauge, eliminates the redundant calibration, reducing the overall testing cost.



- ◆ High Quality Electronic Load cell.
- ◆ 5 Parameter - Weigh, Width, Thickness, Diameter and Hardness up to 500 N, 800 N (optional).
- ◆ Big Graphical Display.
- ◆ Easy Calibration and No Tilt During Calibration.
- ◆ No extra gauges for thickness, all in one measurement.
- ◆ Built in Mini Dot Matrix Printer.
- ◆ On screen statistical view.
- ◆ 3 level Password Protection with real time clock.
- ◆ Self-test and overload protection.
- ◆ No tablet detection.



## Torque Tester for Bottle Caps

The bottle cap torque tester comes with high accuracy and high resolution to measure the torque values. The easy to operate equipment give the torque directions with different types of units.



- ◆ High quality Torque Sensor.
- ◆ Self-Test Feature.
- ◆ Graphical Display.
- ◆ Compact in design.
- ◆ Load cell protection with auto zero calibration.
- ◆ Built in Mini Dot Matrix Printer.
- ◆ 3 Tier Password with real time clock.
- ◆ Customized print reports.

## Tablet Friability Tester

The Tablet Friability Tester is used to find out the ability of the compressed tablet for avoiding fracture and breaking during transportations. The instrument are USP-1216 and EP 2.9.7 compliant.



- ◆ Highly compact and variable speed.
- ◆ Self-Test and validation.
- ◆ Power failure resume.
- ◆ German stepper motor for smooth running.
- ◆ Data transfer to PC.
- ◆ Real time clock with password protection.
- ◆ Built in Mini Dot Matrix Printer.

## Tablet Disintegrating Apparatus

The Tablet Disintegration test apparatus is a solid state instrument designed for the accurate estimation of disintegration time of tablets as per IP/ USP standards. These are used mainly in pharmaceutical industries QC and R&D to determine compliance with disintegration requirements of tablet or capsules as per standards.



- ◆ Complies with USP, IP specifications.
- ◆ Extremely useful for pharmaceuticals labs.
- ◆ Highly accurate and easy to operate.
- ◆ Baskets 'UP' & 'Down' movement as per IP/USP specifications.
- ◆ 20 x 2 line alphanumeric LCD with Backlit.
- ◆ Printer Attachment Facility.
- ◆ Audio visual indicators for system status.



## Saybolt Chromometer



Saybolt Chromometer is used to determine colour numbers of mineral hydrocarbons petroleum waxes and pharmaceutical white oils. This allows to determine.

- ◆ Daylight source built-in the base to project diffused light u.
- ◆ 3-position turret assembly (1/2, 1 and 2) with certified filters.
- ◆ For use on AC 230V-50Hz-0.3 A-180x180x760 mm - (± 8 kg).
- ◆ Conforms to **ASTM D-156**

## 'U' Tube Viscometer

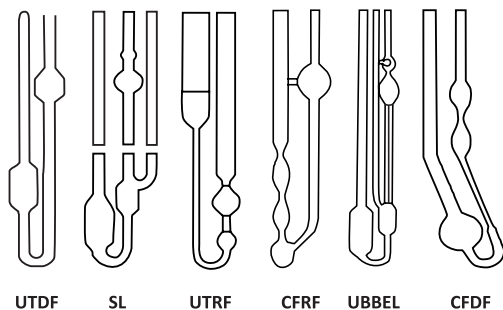

- ◆ Confirms to specifications **ASTM D-445 & 446**.
- ◆ 'U' Tube Reverse Flow / Cannon Fensky Reverse Flow Viscometers for opaque liquid.
- ◆ 'U' Tube Direct Flow / Cannon Fensky Direct Flow.
- ◆ Viscometers for transparent liquid.
- ◆ Suspended Level / Ubbelohde Viscometers for transparent liquid.
- ◆ Supplied with test certificate of constant @40°C or @40°C & 100°C.

## Kinematic Viscosity Bath

ANM Kinematic Viscosity baths used in determination of the viscosity of the fluids. These units confirms to specifications and methods as per **ASTM D-445/446 and IP -71 standards**. The apparatus are supplied with standard accessories used in the method.



- ◆ Double walled constructions, outer body made of heavy gauge mild steel, painted with powder coated paint, inside made of stainless steel.
- ◆ Glass wool insulation to prevent heat loss.
- ◆ Leak proof argon arc welded & fine finished joints.
- ◆ Toughened glass windows with In-built light arrangement.
- ◆ A stirrer for turbulence free agitation & uniform temperature throughout the bath.
- ◆ Digital temperature controller cum indicator and PT-100 sensor.

## Flash Point Apparatus Digital (ABEL - COC - PMCC)

Digital Flashpoint apparatus are designed as per the IP/IS, ASTM standards. .



- ◆ IP 170 / IS : 1448(P 20) [ ABEL ]
- ◆ ASTM D-92, IP 36 & IP 1448 (P-69) [ COC ]
- ◆ ASTM D-93, IP 34 & IS 1448 [ PMCC ]



## H2O Stabilizer

To overcome the tedious job of cleaning, refilling and maintaining the instruments like, Sonicator, Dissolution Apparatus, Water Baths, Circulating Baths, etc. Introducing H2O STABILIZER to prevent / stop / minimize the bacterial / algae / Fungus growth & Foul Smell.



- ◆ Water changing duration is minimized.
- ◆ Heat-transfer efficiency is maintained.
- ◆ The transparency/cleanliness of water is maintained.
- ◆ Biodegradable.
- ◆ Non irritating to skin at recommended concentrations.
- ◆ It can also be used as a general purpose fluid for routine Laboratory applications.

## Universal Statistics Printer

The balance printer USP -100 has a streamlined appearance, completely meets the quality requirements of the chemical and pharmaceutical industry and GLP, GMP standard certification.



- ◆ Various modes of operation for different Applications.
- ◆ Prints Time and Date information when hooked to a balance without clock function.
- ◆ Password Protection for Date / Time Setting.
- ◆ Plug and Play Interfacing.
- ◆ Enhanced Support for ISO/GLP.
- ◆ User Defined Header & Footer.

## Data Logger

ANM Data logger, data acquisition system with its advanced features and 21 CFR compliance Software used to record the temperature / Humidity / Pressure data and prepare the reports. These are used for qualification and calibration of instruments like Ovens, Incubators, stability chambers etc.



- ◆ The software is 21 CFR Part-II Compliant.
- ◆ Common Data Logger for different brand instruments .
- ◆ Uses latest micro controller based technology for better accuracy.
- ◆ Easy on-line field calibration by front panel membrane keypad.
- ◆ Field programmable channel scan time 1 to 59 sec., Logging Interval 1 to 9999 sec. & Printing interval 5 to 9999 sec.
- ◆ Field programmable delay time 1 to 99 sec. for relay output.
- ◆ Optional RS-232 / RS-485 Modbus Serial / Parallel Printer Port.





Lancer is an industry leader in laboratory washing and sterilization products for life science and industrial laboratory applications. With an unmatched variety of models and over four decades of experience, Lancer can meet the specific capacity and cleaning requirements for the utensils and glassware in any laboratory setting while ensuring the best support to customers.

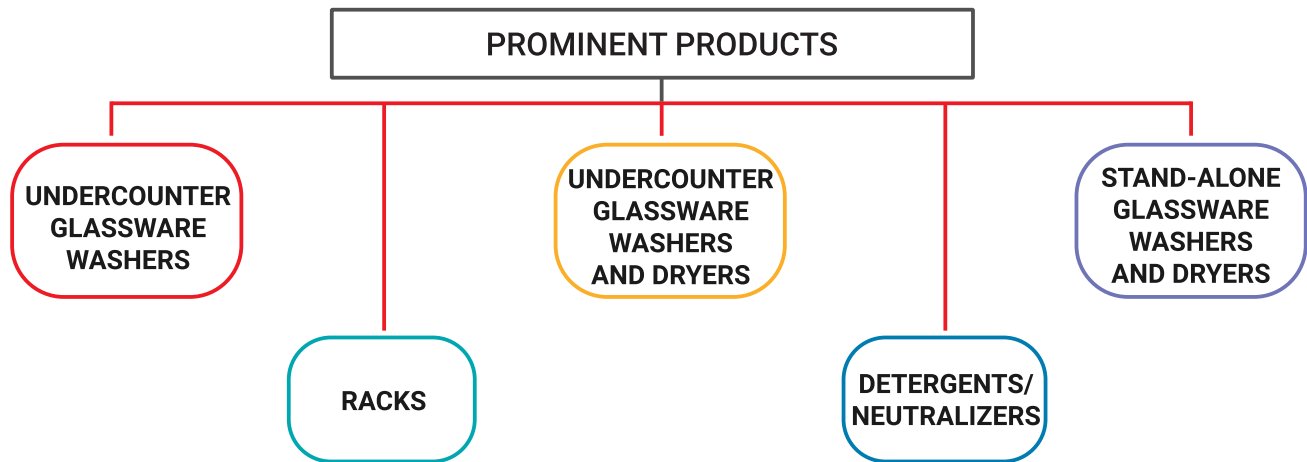

**TECHNOLOGICAL EDGE**

- **Injector drying**  
 Forced air chamber plus Injector drying ensures complete path drying including hydraulic system within the unit and racks. All air is filtered through a high efficiency HEPA filter (purity grade H13).
- **Custom View-in Window**  
 An optional View-In-Process (VIP) window includes an interior LED light for visual verification of the interior load during the cycle and allows the user to gauge that the functioning is currently being accurately executed.
- **Advanced User interface**  
 The Prolux programmable microprocessor controller with intuitive touchscreen user interface helps easy user interaction along with a control screen that shows actual cycle performance, alarm events. Data is captured for documentation and communication (through USB port).

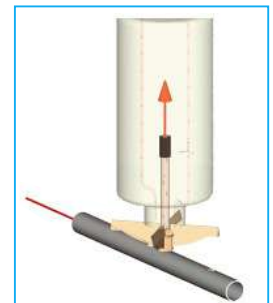

**Injector Drying**

**REAL WORLD APPLICATIONS**

- **Pharma, Biotech, Chemical**  
 Microbiology glasswares can be cleaned by Agarose Gel(Program No 4) cycle developed by Lancer. QC/Analytical glasswares can be cleaned without pre-rinse in case of non-sticky samples in glasswares. For sticky materials in QC or Analytical R&D labs users will have to do pre-rinse with solvents for eg or other chemicals and from second phase they can load in glassware washer.
- **Research Institutes**  
 Biological Sciences department can use Agarose Gel cycle (program No 4) to clean lab glasswares. Chemical department can use any other cycle out of 4 standard cycles from Lancer to clean various types of glasswares.
- **FMCG**  
 QC labs, Microbiology labs can use any of the 5 standard cycles to clean lab glasswares.





**Lancer Ultima 810LX** - Undercounter Glassware Washer with 2 racks capacity.



- ◆ Capacity : 2 wash levels/ 2 racks.
- ◆ Possible to wash & dry 200 glassware's at a time.
- ◆ Human Interface: Color touch screen 3,5" – TFT display.
- ◆ 5 standard, 35 customizable programs.
- ◆ Optional View-In-Process (VIP) Window.
- ◆ Standard USB port.
- ◆ Supports multi-function rack and rack interchangeability within Lancer models.

**Lancer 815LX/820LX** - Undercounter Glassware Washer & Dryer with 2 racks capacity.



- ◆ Capacity : 2 wash levels/ 2 racks.
- ◆ Possible to wash & dry 200 glassware's at a time.
- ◆ Human Interface: Color touch screen 3,5" – TFT display.
- ◆ 5 standard, 35 customizable programs.
- ◆ Optional View-In-Process (VIP) Window.
- ◆ Standard USB port.
- ◆ Inbuilt water softener in Lancer 820LX.
- ◆ Hot forced air drying in 815LX, Hot forced air drying plus injector drying in 820LX.
- ◆ Supports multi-function rack and rack interchangeability within Lancer models.

**Lancer 1300LX/1400LX/1400LXP** - Freestanding Glassware Washer & Dryer with 3 racks capacity.



- ◆ Capacity : 3 wash levels/ 3 racks.
- ◆ Possible to wash & dry 300 glassware's at a time.
- ◆ Human Interface: Color touch screen 3,5" – TFT display.
- ◆ 1400LXP having color touch screen 7" – TFT display.
- ◆ 5 standard, 35 customizable programs.
- ◆ Optional View-In-Process (VIP) Window.
- ◆ Standard USB port.
- ◆ Hot forced air drying plus injector drying
- ◆ Supports multi-function rack and rack interchangeability within Lancer models.



**Lancer 1600LXP - Freestanding Glassware Washer & Dryer with 4 racks capacity**



- ◆ Capacity : 4 wash levels/ 4 racks.
- ◆ Possible to wash & dry 400 glassware's at a time.
- ◆ Human Interface: Color touch screen 7" – TFT display.
- ◆ 5 standard, 35 customizable programs.
- ◆ Optional View-In-Process (VIP) Window.
- ◆ Standard USB port.
- ◆ Hot forced air drying plus injector drying.
- ◆ Supports multi-function rack and rack interchangeability within Lancer models.

**Lancer 1800LXA - Freestanding Glassware Washer & Dryer with 6 racks capacity.**



- ◆ Capacity : 6 wash levels/ 6 racks.
- ◆ Biggest Glassware washer in the industry, capable of washing 600 glasswares at a time.
- ◆ Chamber divided in 2 parts with 3 wash levels/ 3 racks on each side.
- ◆ Human Interface: Color touch screen 7" – TFT display.
- ◆ 5 standard, 35 customizable programs.
- ◆ Optional View-In-Process (VIP) Window.
- ◆ Standard USB port.
- ◆ Hot forced air drying plus injector drying
- ◆ Supports multi-function rack and rack interchangeability within Lancer models.

**Accessories/Consumables - Seamless and interchangeable racks as well as Detergent(FLD)and Neutralizer(FLN).**



**Injector Racks**



**Multi-purpose Racks**



**FLD and FLN**



Nabertherm GmbH has been developing and producing furnaces for many different applications for 70 years. As a manufacturer, Nabertherm offers a wide and deep range of furnaces and is committed to excellent design, quality and cost-efficiency.

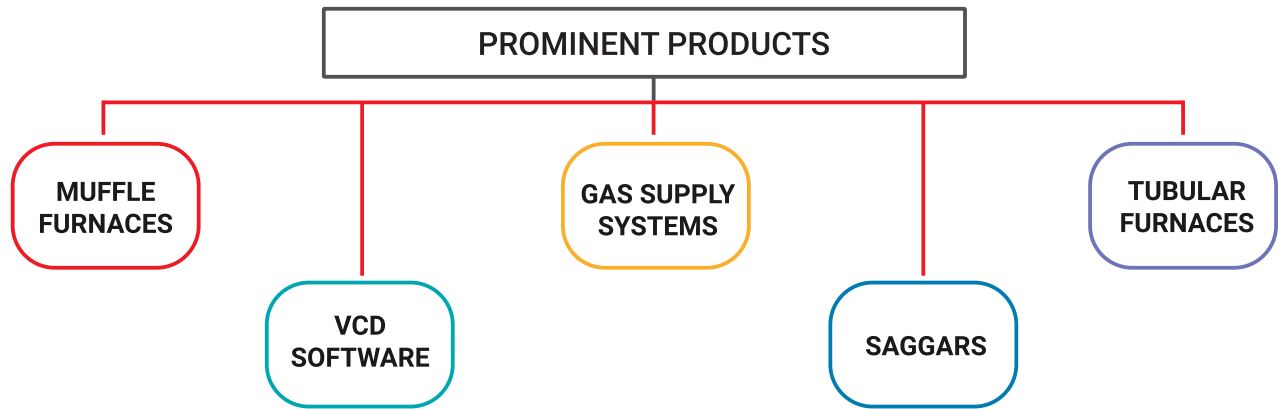

### TECHNOLOGICAL EDGE

#### - Dual Shell housing

The unique dual shell housing in Nabertherm acts as an excellent safety measure which allows low external temperatures (outside furnace) despite of high stable temperatures above 1000C inside the furnace.

#### - Fiber Insulation

In addition to providing excellent insulation and durability for the furnace, the material is non-carcinogenic according to measure TRGS 905, Class 1 or 2. This provides safety to the user even with continuous contact (through air) with the furnace under standard operating conditions.

### REAL WORLD APPLICATIONS

#### - Pharmaceuticals/Food Industries (Ashing)

Ashing is a test to deduce the amount of ash/undesirable contaminants or impurities forming material present in a product by heating at higher temperatures.

#### - Automobile Industries (Heat treatment/Annealing)

Process in which we heat metal or glass using furnace and allow it to cool slowly, in order to remove internal stresses and toughen it.

#### - Research Institutes (Sintering)

Sintering is the process of compacting and forming a solid mass of material by heat using a furnace without melting it to the point of liquefaction.

#### - Paint (Heat Treatment)

Heat treatment in paint industries is a process in which we test the paint coated products and its withstanding capability by heating at higher temperature using a furnace.

#### - Cement Industries (Burnability tests)

Burnability test is a process where a particular product is converted to granular form, heated at various temperatures and then a note is made of the temperature at which the product gets burnt.

**\*Note: Models with TMax up to 3000°C are also available based on user's requirement for specific applications.**



## Muffle Furnace with Tmax 1100°C -1300°C

These furnaces are the right choice for daily Laboratory use due to advanced and attractive design and high reliability.



- ◆ Dual Shell Housing made of Textured Stainless Steel for low external Temperature and high stability.
- ◆ Flap door and Lift door Options available.
- ◆ Ceramic heating plates with integral heating element or heating elements on support tubes.
- ◆ Recording of process data using USB-flash drive.
- ◆ Fiber Insulation that are not classified as Carcinogenic according to TRGS 905, class 1 or 2. / Lightweight refractory Brick insulation also available.

## Muffle Furnaces with Tmax 1400°C-1600°C

The durability of SiC rods heating elements, in combination with their high heating speed, make these furnaces an all-rounder for Laboratory use.



- ◆ Dual Shell Housing made of Textured Stainless Steel for low external temperature and high stability.
- ◆ Flap door and Lift door options available.
- ◆ Silicon Carbide (SiC) heating elements on two sides of furnace.
- ◆ Recording of process data using USB-flash drive.
- ◆ Fiber Insulation that are not classified as Carcinogenic according to TRGS 905, class 1 or 2.

## Muffle Furnace with Tmax 1600°C-1800°C

Designed as both Table-top and stand-alone models, hence these furnaces are used for processes in Laboratory where the highest precision is needed. Outstanding temperature uniformity and practical details set unbeatable quality benchmarks.



- ◆ Dual Shell Housing made of Textured Stainless Steel for low external Temperature and high stability.
- ◆ Flap door and Lift door Options available.
- ◆ Molybdenum di silicide (MoSi<sub>2</sub>) heating elements on two sides of furnace.
- ◆ Recording of process data using USB-flash drive.
- ◆ Fiber Insulation that are not classified as Carcinogenic according to TRGS 905, class 1 or 2.



## Tubular Furnace with Tmax 1100°C-1300°C

These compact tube furnaces with integrated control systems can be universally used for many processes. Due to the design, it allows comfortable exchange of various working tubes.



- ◆ Dual Shell Housing made of Textured Stainless Steel for low external Temperature and high stability.
- ◆ Fiber Insulation that are not classified as Carcinogenic according to TRGS 905, class 1 or 2.
- ◆ Horizontal and vertical operation models available with split design.
- ◆ Single zone and three zone models available.
- ◆ Varied range of diameter and heated length available.
- ◆ Recording of process data using USB-flash drive.
- ◆ Gas purging and vacuum options available.

## Tubular Furnace with Tmax 1500°C

These are Compact tube furnace with Silicon Carbide heating element installed parallel ensures excellent temperature uniformity, also it had an integrated switchgear and controller for ease of use.



- ◆ Dual Shell Housing made of Textured Stainless Steel with Active cooling facility for low external Temperature and high stability.
- ◆ Fiber Insulation that are not classified as Carcinogenic according to TRGS 905, class 1 or 2.
- ◆ 99.7% Alumina Working tube as standard.
- ◆ Recording of process data using USB-flash drive.
- ◆ Silicon Carbide (SiC) heating elements.
- ◆ Working tube of 80mm diameter as standard with heated length options of 230mm, 450mm and 710mm available.
- ◆ Gas purging and vacuum options available.

## Tubular Furnace with Tmax 1600°C-1800°C

These type of furnace is equipped with high quality insulation that enables energy saving operation and fast heating time due to low heat storage and heat conductivity.



- ◆ Dual Shell Housing made of Textured Stainless Steel for low external Temperature and high stability.
- ◆ Rectangular outer housing with slots for Convection cooling.
- ◆ Fiber Insulation that are not classified as Carcinogenic according to TRGS 905, class 1 or 2.
- ◆ Horizontal and vertical operation models available.
- ◆ Varied range of diameter and heated length available.
- ◆ Recording of process data using USB-flash drive.
- ◆ Gas purging and vacuum options available.





Hirayama Manufacturing Corporation, have been a pioneer in Manufacturing Autoclaves since 90 years, and have been serving Pharmaceutical companies, Research companies, Food industry, Institutes and Government Organizations. In order to meet the diversifying needs of the users, Hirayama continue to provide superior products by utilizing reliable technology and complete service system backed by a lot of experience.

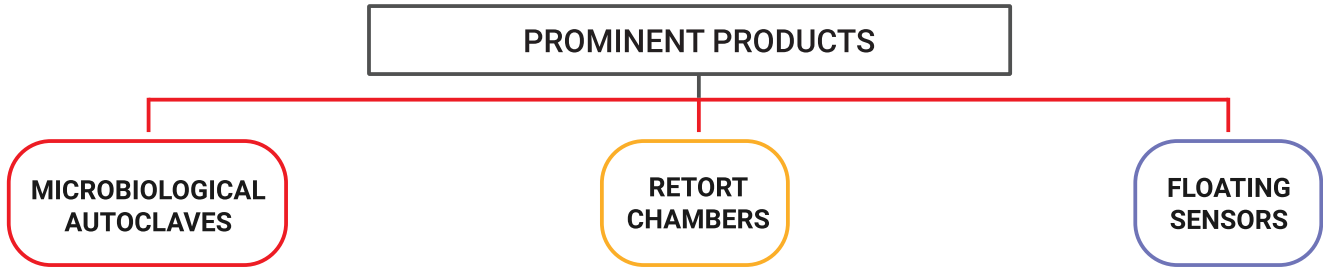

## TECHNOLOGICAL EDGE

- **User Friendly Controllers**
  - a. Touchscreen (For HV-II)
  - b. Touch Button Controller (For HG/HVE/HLM)
- **Lid Lock**
  - a. Electromechanical Lid lock system with dual interlock mechanism.
- **Multiple Operation Modes**
  - Liquid Mode
  - Solid Mode
  - Waste Mode
  - Agar Mode
  - Dissolution Mode
- **Sterilization Cycles**
  - Natural Cooling
  - Shower Cooling (without pressure control)
  - Shower cooling (with pressure control)



**\*Cools faster than other Autoclaves**



## HV-II Series

These Autoclaves are user friendly, reliable and safe by its newly launched Color touch panel display.



- ◆ Sterilization Temperature: 126°C or 135°C.
- ◆ Capacity from 25-110 liters.
- ◆ Easy to operate Color-touch Panel.
- ◆ 4 Selectable modes: Agar, Solid, Dissolution, Liquid.
- ◆ Electromechanical Lid Lock System.
- ◆ Selectable exhaust level.
- ◆ Optional devices: Printer/Recorder, Floating Sensor, Forced cooling Device, Automatic water supply system.

## HVE Series

These autoclaves are the basic and one of the most economical model of Hirayama Autoclave portfolio with a compact design and easy to use controller mounted on the lid.



- ◆ Sterilization Temperature: 105°C to 135°C.
- ◆ Capacity from 50 liters.
- ◆ Electromechanical Lid Lock System.
- ◆ Pulse exhaust system.
- ◆ Dual Sensing interlock mechanism.
- ◆ Process status display.
- ◆ Programmable modes and memory function.

## HG-II Series

A new-generation autoclave that features the advanced function and the enhanced user-friendliness as well as the automated lid operation system is born.



- ◆ Sterilization Temperature: 105°C to 135°C.
- ◆ Capacity : 50 and 80 liters.
- ◆ One touch lid open close function.
- ◆ Selectable exhaust level.
- ◆ Process status display.
- ◆ 4 Selectable modes: Agar, Solid, Dissolution, Liquid.
- ◆ Optional devices: Printer/Recorder, Floating Sensor, Forced cooling. Device, Automatic water supply system.



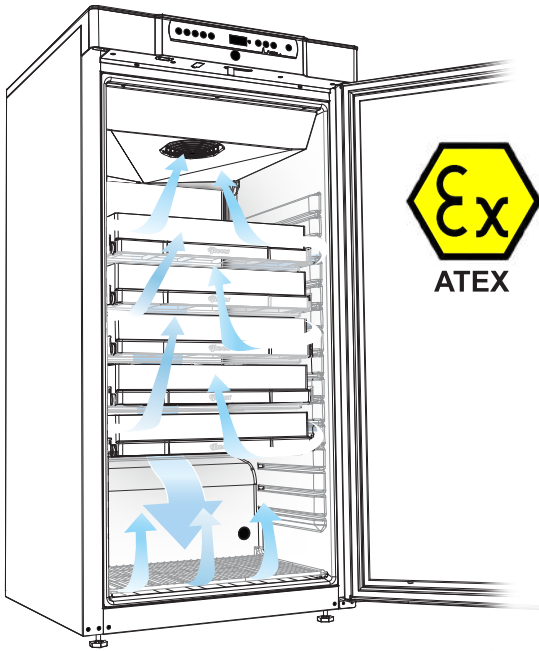

- Optimised air flow ensures  
**TEMPERATURE UNIFORMITY**

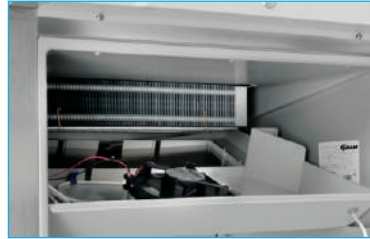

- Finned Tube Evaporator  
Better stability ensures  
**NO COLD WALLS**



- Control Panel with  
temperature display,  
audio/visual alarms



Environmental  
Friendly - CFC  
free refrigerant



Low Power  
Consumption

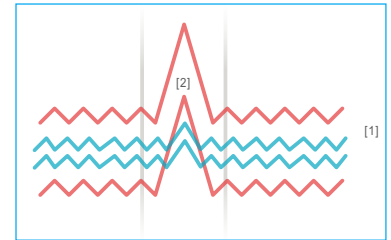

- Smart Auto-deforst  
(Conventional Defrosting vs  
Gram Defrosting Graph)

## B SCIENCE

Bscience Refrigerators & Freezers are designed, constructed and manufactured in Denmark with high performance refrigeration systems. Bscience uses isolation thickness of 70mm to maximize the temperature stability.

- In-Built Data Logger
- Temperature with date and time
- Data Memory for 15 years
- Password Protected
- Data Upload / Download by USB
- Full Documentation
- IQ/OQ/PQ
- Production Qualification Test



- Touch Screen Display

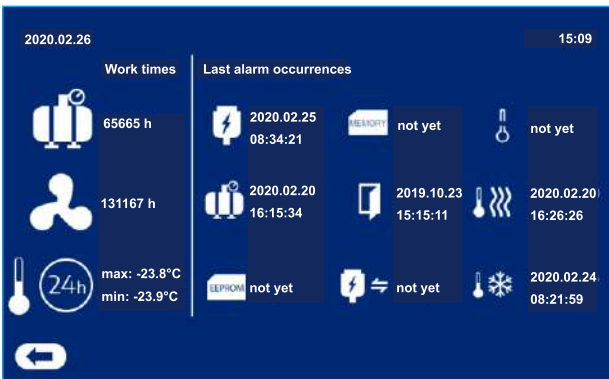

- Alarms for every malfunction

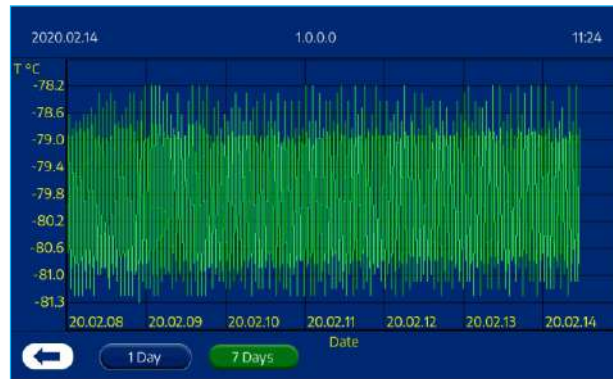

- Temperature Graph



## BioCompact II - ATEX certified refrigerators and freezers

The BioCompact II provides you with significantly better performance than any other cabinets for storing ordinary biomaterials under stable conditions.



- ◆ Capacity ranging from 104Litres to 583Litres.
- ◆ Temperature range: +2 to +20°C, -25 to -5°C.
- ◆ Temperature Monitoring & visual/acoustic alarms.
- ◆ Automatic Smart Defrost with re-evaporation of defrost water.
- ◆ Unique Air Distribution System to ensure temperature stability.
- ◆ Interior : ABS lining ; Exterior: White lacquered steel or Stainless Steel finish.
- ◆ Wire shelves and perforated shelves available in Stainless Steel.

## BioBasic - ATEX certified refrigerators and freezers

With temperature alarms, internal and external ATEX, no cold walls and a user friendly interface, the BIOBASIC range provides an exceptional selection of features in a very small package.



- ◆ ATEX certified industrial refrigerators and freezers.
- ◆ Capacity ranging from 104Litres to 346Litres.
- ◆ Temperature range: +2 to +15°C, -25 to -5°C.
- ◆ Temperature Monitoring & visual/acoustic alarms.
- ◆ Automatic Smart Defrost with re-evaporation of defrost water.
- ◆ Unique Air Distribution System to ensure temperature stability.
- ◆ Interior : ABS lining ; Exterior: Lacquered steel.
- ◆ Wire shelves and perforated shelves available in Stainless Steel.

## Compact - ATEX certified refrigerators and freezers

Compact refrigerator or freezer cabinets for a wider range of storage purposes where the prime focus is on dependability.



- ◆ Industrial refrigerators and freezers
- ◆ Capacity ranging from 104Litres to 583Litres
- ◆ Temperature range: +2 to +12°C, -22 to -5°C.
- ◆ Temperature Monitoring & visual/acoustic alarms.
- ◆ Automatic Smart Defrost with re-evaporation of defrost water.
- ◆ Unique Air Distribution System to ensure temperature stability.
- ◆ Interior : Grey ABS or White ABS ; Exterior: White lacquered or stainless steel.
- ◆ Wire shelves and perforated shelves available in Stainless Steel.



## Industrial Refrigerators

Mono-block refrigeration systems which optimize the chamber capacity while providing temperature stability.



- ◆ Capacity range 628Litres and 1398Litres.
- ◆ Temperature range: +1 to +10°C.
- ◆ Integrated Data Logger with memory.
- ◆ RS485 interface, Ethernet connection.
- ◆ Visual & Acoustic Alarms: High/Low, power failure, open door, probe failure, remote alarm, 48 hours battery backup for logging alarms & temperature display in case of power failure.
- ◆ USB for memory over 15 years of data.
- ◆ Interior material: Stainless Steel ; Exterior material: Powder coated Galvanised Steel.
- ◆ Password protected, GSM module.

## Industrial Freezers

Mono-Block refrigeration system is used to optimize the chamber capacity and have isolation thickness of 70mm to maximize the temperature stability in freezers.



- ◆ Capacity range 628Litres and 1398Litres.
- ◆ Temperature range: -10 to -30°C.
- ◆ Integrated Data Logger with memory.
- ◆ RS485 interface, Ethernet connection.
- ◆ Visual & Acoustic Alarms: High/Low, power failure, open door, probe failure, remote alarm, 48 hours battery backup for logging alarms & temperature display in case of power failure.
- ◆ USB for memory over 15 years of data.
- ◆ Interior material: Stainless Steel ; Exterior material: Powder coated Galvanised Steel.
- ◆ Password protected, GSM module.





Lamy Rheology is recognized around the world for offering high quality rheometers and viscometers at an affordable price. It has been the rheology industry for over 65 years. Their ever expanding portfolio includes economical and easily portable viscosity analysis instruments for accurate measurement under an extended range with options for varying physical characteristics.

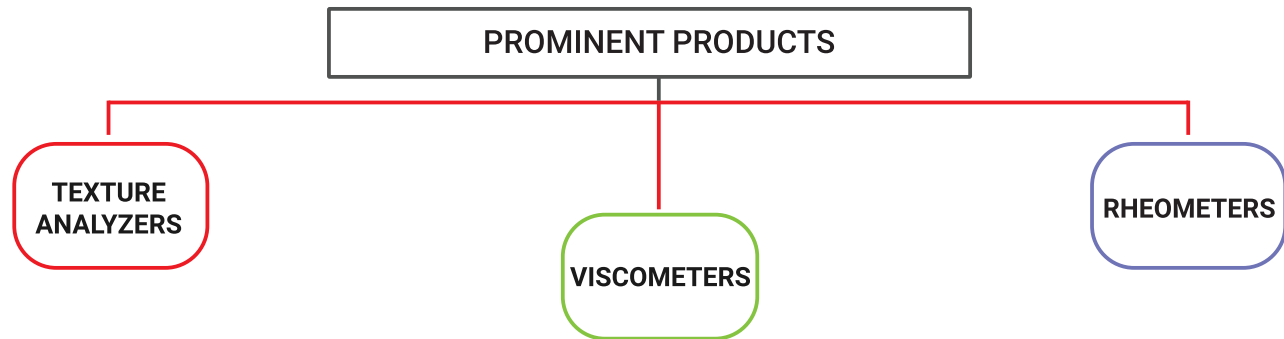

### TECHNOLOGICAL EDGE

- **EZ spindle attachment**  
The unique bayonet fitting system allows quick attachment to the Viscometer and also reduces breakage of the individual spindles.
- **Leveled viscometer**  
As the viscometer head is already spirit leveled, there is no need to level the instrument every time before using.
- **User friendly**  
Lamy instruments all have a touch screen display, are light weight, and portable. These unique features allow the user to carry out measurement with ease.

### REAL WORLD APPLICATIONS

- **Pharmaceutical Industry**  
Helps gauge topical products in terms of spread ability and adhesiveness to ensure standard quality and select adaptable packaging material.
- **Food Industry**
  - a. Chocolate – Viscometer with Small sample adapter at constant temperature is advised worldwide for checking viscosity and NCA / CMA (Casson model).
  - b. Beverages – Lamy Viscometers are used in Beverage industry for checking viscosity of juices, pulps, concentrates providing best accuracy in testing.
- **Paint Industry**  
Viscometers help the paint industry in dip coating thickness control which ensures an even spread of the product. Similar applications are present for capsules and batter as well.



## B-ONE Plus

The ONLY Touch Screen Viscometer in its class to offer continuous sensing & data display



- ♦ 7" Touch Screen Display.
- ♦ Wide Speed Range upto 250rpm.
- ♦ Rotating Spring Less Technology.
- ♦ Robust Ball Bearing Suspension.
- ♦ SS316 Spindles.
- ♦ Bayonet Fitting for Quick & EZ Spindle Connection.
- ♦ Direct measure with Time to Stop.
- ♦ Built-in USER Mode & LOCK Mode.
- ♦ Built-in USB Port for Data Transfer.
- ♦ Units: cP (Centipoise), mPa.s/Pa.s(Poise)
- ♦ Accuracy: 1% of Full-Scale Range
- ♦ Readability: +/- 0.2%
- ♦ Displays: Viscosity, Speed, Torque(%), Shear Stress, Shear Rate, Time, Temperature (Optional probe required)
- ♦ Auto Range (Min. & Max. Viscosity) (Range depends on speed & spindle selected)

- Two Viscometer Range!
  - LV & RV in 1 Viscometer (LR)
  - RV, HA - 5HB in 1 Viscometer (HR)
- Exactly same matching comparing results

## B-ONE Plus KU

The ONLY Touch Screen Viscometer in its class to offer continuous sensing & data display for Paints, Coatings & inks



- ♦ ASTM D562 Compatible (Industry Specifications)
- ♦ 7" Touch Screen Display.
- ♦ Wide Speed Range upto 250rpm.
- ♦ Rotating Spring Less Technology.
- ♦ Robust Ball Bearing Suspension.
- ♦ SS316 Spindles.
- ♦ Bayonet Fitting for Quick & EZ Spindle Connection.
- ♦ Direct measure with Time to Stop.
- ♦ Built-in USER Mode & LOCK Mode.
- ♦ Built-in USB Port for Data Transfer.
- ♦ Units: KU (KREBS) cP (Centipoise), mPa.s/Pa.s(Poise)
- ♦ Accuracy: 1% of Full-Scale Range
- ♦ Readability: +/- 0.2%
- ♦ Displays: Viscosity, Speed, Torque(%), Shear Stress, Shear Rate, Time, Temperature (Optional probe required)
- ♦ Auto Range (Min. & Max. Viscosity) (Range depends on speed & spindle selected)

- Multi Viscometer Range!
  - KU, RV, HA - 5HB in 1 Viscometer (KU)
- Exactly same matching comparing results



## First Plus

The ONLY Touch Screen Viscometer in its class to offer continuous sensing & data display. With its expanded functions possibilities and increased modularity, the FIRST PLUS will be the ideal tool for your application whether you use it alone or with its software.



- ◆ 7" Touch Screen Display.
- ◆ Wide Speed Range upto 250rpm.
- ◆ Rotating Spring Less Technology.
- ◆ Robust Ball Bearing Suspension.
- ◆ SS316 Spindles.
- ◆ Bayonet Fitting for Quick & EZ Spindle Connection.
- ◆ Direct measure with Time to Stop.
- ◆ Built-in Temperature Probe.
- ◆ Built-in USER Mode & LOCK Mode.
- ◆ Built-in USB & Rs232 Port for PC/Printer Connection.
- ◆ Optional RheoTex software.
- ◆ Units: cP (Centipoise), mPa.s/Pa.s(Poise)
- ◆ Accuracy: 1% of Full-Scale Range
- ◆ Readability: +/- 0.2%
- ◆ Displays: Viscosity, Speed, Torque(%), Shear Stress, Shear Rate, Time, Temperature
- ◆ Auto Range (Min. & Max. Viscosity) (Range depends on speed & spindle selected)

- Two Viscometer Range!
  - LV & RV in 1 Viscometer (LR)
  - RV, HA - 5HB in 1 Viscometer (HR)
- Exactly same matching comparing results

## First PRODIG

The ONLY Touch Screen Viscometer in its class to offer continuous sensing & data display. FIRST PRODIG allows to create & save measurement methods, display results or curves, analyze data, print reports, manage users and protect data.



- ◆ 7" Touch Screen Display.
- ◆ Wide Speed Range upto 250rpm.
- ◆ Rotating Spring Less Technology.
- ◆ Robust Ball Bearing Suspension.
- ◆ SS316 Spindles.
- ◆ Bayonet Fitting for Quick & EZ Spindle Connection.
- ◆ Speed or Shear rate control
- ◆ Direct measure with Time to Stop.
- ◆ Programming and Recording Method.
- ◆ Data recording & USB Transfer.
- ◆ Constant, step by step or ramp methods.
- ◆ Direct curve on display.
- ◆ Direct analysis with regression.
- ◆ Direct report editing.
- ◆ Built-in Temperature Probe.
- ◆ Built-in USER Mode & LOCK Mode.
- ◆ Built-in USB & Rs232 Port for PC/Printer Connection.
- ◆ Optional RheoTex software.
- ◆ Units: cP (Centipoise), mPa.s/Pa.s(Poise)
- ◆ Displays: Viscosity, Speed, Torque(%), Shear Stress, Shear Rate, Time, Temperature, Curve (graphs)
- ◆ Auto Range (Min. & Max. Viscosity) (Range depends on speed & spindle selected)

- Two Viscometer Range!
  - LV & RV in 1 Viscometer (LR)
  - RV, HA - 5HB in 1 Viscometer (HR)
- Exactly same matching comparing results



## First PRODIG CP1000

The ONLY Touch Screen Viscometer in its class to offers unparalleled ease of use and modularity with continuous sensing & data display. FIRST PRODIG incorporates a support for cone-plate measurements and allows to create & save measurement methods, display results or curves, analyze data, print reports, manage users and protect data. Its versatility allows it to use other measuring systems such as RV Spindles, VANE Spindles, KREBS KU Spindles.



- ♦ Touch Screen Display.
  - ♦ Wide Speed Range upto 250rpm.
  - ♦ Rotating Spring Less Technology.
  - ♦ Robust Ball Bearing Suspension.
  - ♦ Quick attachment with AC265 coupling.
  - ♦ SS316 Spindles.
  - ♦ Bayonet Fitting for Quick & EZ Spindle Connection.
  - ♦ Removable Bottom Plate.(w/integrated temperature probe)
  - ♦ Manual lift for gap adjustment.
  - ♦ Speed or Shear rate control.
  - ♦ CP1000 Stand for C/P measurement.
  - ♦ Programming and Recording Method.
  - ♦ Direct measure with Time to Stop.
  - ♦ Constant, step by step or ramp methods.
  - ♦ Direct curve on display
  - ♦ Direct analysis with regression
  - ♦ Direct report editing
  - ♦ Data recording & USB Transfer
  - ♦ Optional RheoTex software.(CFR Option).
  - ♦ Units: cP (Centipoise), mPa.s/Pa.s(Poise).
  - ♦ Displays: Viscosity, Speed, Torque(%), Shear Stress, Shear Rate, Time, Temperature, Curve (graphs)
  - ♦ Auto Range (Min. & Max. Viscosity) (Range depends on speed & spindle selected)
- Multi Viscometer Range!  
- (CP & Rotational Viscometer) in 1 Viscometer C/P, RV, HA-5HB, VANE, Krebs-KU
  - Exactly same matching comparing results

## RM100 CP1000+

The all-in-one tool for measuring viscosity and yield stress with Cone and Plate measuring systems adapted for samples in limited quantities and difficult to clean. The ONLY Touch Screen Cone and Plate Viscometer in its class to offer continuous sensing & data display with broadest range of Speeds and Torque! And yet compatible which can use RV, LV, VANE or Cone plate/CAP spindle!



- ♦ 7" Touch Screen Display.
  - ♦ Wide Range of CAP#01-#10 Spindles.
  - ♦ Wide Range of CPA#40Z-52Z Spindles.
  - ♦ Robust Ball Bearing Suspension.
  - ♦ AC265 coupling system for Ss316 Cone Plate.
  - ♦ SS316 Spindles (LV/RV/VANE).
  - ♦ Bayonet Fitting for Quick & EZ Spindle Connection.
  - ♦ Removable Bottom Plate.(w/integrated temp. probe)
  - ♦ New Gap Adjustment Ring.
  - ♦ Guaranteed Easy Cleaning.
  - ♦ CONE/PLATE Spring Less Technology
  - ♦ Programming and Recording Method.
  - ♦ CP1000 Stand for C/P measurement.
  - ♦ Direct report editing.
  - ♦ Data recording & USB Transfer
  - ♦ Built-in USER Mode & LOCK Mode.
  - ♦ Built-in USB & Rs232 Port for PC/Printer Connection.
  - ♦ Optional RheoTex software.
  - ♦ Units: cP (Centipoise), mPa.s/Pa.s(Poise)
  - ♦ Displays: Viscosity, Speed, Torque(%), Shear Stress, Shear Rate, Time, Temperature
  - ♦ Auto Range (Min. & Max. Viscosity) (Range depends on speed & spindle selected)
- Multi Viscometer Range!  
- (CP & Rotational Viscometer) in 1 Viscometer CAP, CP, RV, HA-5xHB, KU
  - Cover High Torque 181,000 dyne cm ICI Specifications method
  - Covers Low Torque 7,970 dyne cm (123CAP)
  - Wide Shear Range! 1-20,000 sec<sup>-1</sup>
  - Exactly same matching comparing results



## RM100 CP2000+

The all-in-one tool for measuring viscosity and yield stress with Cone and Plate measuring systems adapted for samples in limited quantities and difficult to clean. The ONLY Touch Screen Cone and Plate Viscometer in its class to offer continuous sensing & data display with broadest range of Speeds and Torque!



- ◆ 7" Touch Screen Display.
- ◆ Wide Range of CAP#01-#10 SS316 Spindles.
- ◆ Wide Range of CPA#40Z-52Z SS316 Spindles.
- ◆ Robust Ball Bearing Suspension.
- ◆ AC265 coupling system for Cone Plate.
- ◆ Removable Bottom Plate. (w/integrated temp. probe)
- ◆ New Gap Adjustment Ring.
- ◆ Guaranteed Easy Cleaning.
- ◆ CONE/PLATE Spring Less Technology.
- ◆ Programming and Recording Method.
- ◆ Direct report editing.
- ◆ Data recording & USB Transfer
- ◆ Built-in USER Mode & LOCK Mode.
- ◆ Built-in USB & Rs232 Port for PC/Printer Connection.
- ◆ Optional RheoTex software.(CFR option)
- ◆ Units: cP (Centipoise), mPa.s/Pa.s(Poise)
- ◆ Displays: Viscosity, Speed, Torque(%), Shear Stress, Shear Rate, Time, Temperature
- ◆ Auto Range (Min. & Max. Viscosity) (Range depends on speed & spindle selected)

- Multi Viscometer Range!  
- (CP & Rotational Viscometer) in 1Viscometer CP models & CAP models
- Cover High Torque 181,000 dyne cm ICI Specifications method
- Covers Low Torque 7,970 dyne cm (123CAP)
- Wide Shear Range! 1-20,000 sec<sup>-1</sup>
- Exactly same matching comparing results

## RHEOTEX SW

The new RheoTex software developed by LAMY RHEOLOGY allows control of all instruments (except: B-ONE PLUS). The license file associated with the software allows you to automatically configure software to be compatible with instrument. Since the software base is the same, only an additional license is required when you have two devices to control by RheoTex.



- ◆ Creation and saving of methods
- ◆ Transfer data from device memory
- ◆ Temperature ramp method
- ◆ Use of mathematical tools for data analysis.
- ◆ Creation of free program
- ◆ PDF report editing
- ◆ Compatible with office software or experience creation
- ◆ Automatic measurement and analysis
- ◆ Optional upgrade to 21 CFR Part 11 Compatible compliance version

### Additional Functions for FIRST Series & RM100

- ◆ Mathematic analysis of results
- ◆ Functions for Viscometer Instrument Control, Method Viscosity (Over time), Methods Free Program, Loop Mode, Control of temperature Unit, and Direct Curve while testing
- ◆ Rheological models calculations
- ◆ Method Flow Curve & Logarithmic functions (Only on FIRST PRODIG Model)





## TX700

With its wide range of probes and fixtures, the TX 700 is the ideal tool for your texture analysis. Thanks to its touch screen directly displaying the curves, its method programming capability, storage and analysis of measurements, the TX 700 will fit in laboratory and production area.



- ♦ Integrated temperature probe.
- ♦ Direct curve on display.
- ♦ Programming and recording methods.
- ♦ Data recording and USB transfer.
- ♦ Many different probes and fixtures.
- ♦ Interchangeable force sensors.
- ♦ Height adjustable tray.
- ♦ Compatible with RheoTex software.

### What benefits are there for you?

- Integrated adjustable turntable: diam. 160 mm.
- Table for attaching inserts: 120 x 220 mm
- Available Operating Modes:
  - a. Compression
  - b. Relaxation
  - c. Traction
  - d. TPA Cycle
  - e. Penetrometry and Relative compression mode also.
- Large selection of probes available and custom probes can be made with choice of material, shape and size according to your criteria.
- The TX700 has a large 7" colour touch screen which allows comfortable use and optimal viewing of measurements.
- Storage of your measuring methods. Data can be backed up and exported using a USB stick.
- External control thanks to the optional software.

Tx700 Texture Analyzer is suitable for various types of analysis such as Hardness, Adhesiveness, Cohesiveness, Brileness, Elascity Modulus, Gumminess, Chewiness, etc. in Pharmaceucals, Food, Cosmecs, Materials Tesng, etc. such as: Gel Strength, Gelan Bloom Strength, Break Strength, Burst Point, Compressibility, Consistency, Extensibility, Firmness, Flexibility, Fracturability, Fricon, Peel Strength, Puncture Force, Relaxaon, Resilience, Seng/Curing, Spreadability, Springiness, Stiffness, Swelling, Tackiness, Tear Strength, Tensile Strength, Toughness, Compression tests (piercing, penetration, and break analysis tests), tensile tests, texture tests (two-bite method), indentation tests, gel strength tests, shear/cutting tests, adhesiveness tests, hardness tests, and more.



## ACCESSORIES

### MS-SV (Small Volume Package)

LAMY RHEOLOGY MS-SV Measuring System for Low/Small Volume Viscosity Measurement.

This measuring system makes it possible to measure products in small quantities by applying a shear rate. Cylindrical geometry provides calculable shear rates, which allow the user to predict a product's reaction to shear stress.

The Small Volume Package Measuring System, consisting of a cylindrical sample chamber and spindle, provides a defined geometry system for accurate viscosity measurements of small sample volumes in the order of 3 to 13 mL at precise shear rates. The MS-SV rheologically correct cylindrical geometry provides extremely accurate viscosity measurements and shear rate determinations.



- ◆ For rheological evaluation of materials where sample volume is limited.
- ◆ Sample chamber easily changed.
- ◆ Optional disposable chamber also available.
- ◆ Optional Water jacket allows rapid and precise temperature control of sample.
- ◆ Simultaneous sample temperature measurement (optional for B-One Plus series).

### MS-ULV (Ultralow Viscometer Measurement Package)

LAMY RHEOLOGY MS-ULV Measuring System for Ultra Low Viscosity Measurement up to 1cP (centipoise). This measuring system makes it possible to measure low viscosity products in control by applying shear rate.

The MS-ULV Ultra Low Viscosity Package is used with any LAMY Laboratory Viscometer and Rheometer to make accurate and reproducible measurements on low viscosity materials. Newtonian and non-Newtonian materials can be measured. Its rheologically correct cylindrical geometry provides extremely accurate viscosity measurements and shear rate determinations.



- ◆ Ideal for low viscosity materials.
- ◆ Small sample size: 11 mL
- ◆ SS#316 Stainless steel parts are easily cleaned.
- ◆ Reduces measuring range to as low as 1 cP (LR Model).
- ◆ Cylindrical geometry provides defined shear rates for detailed product analysis.

### THERMOCELL Package

LAMY RHEOLOGY THERMOCELL System designed for Viscosity measurement at Elevated Temperature up to 300 deg C. Ideally suitable for High Temperature measurement applications in Polymers (ASTM D3236), Hot Melts, Wax, Asphalts (ASTM D4402), etc. P/N N130150.



The difficulty with viscosity measurements of hot melts and liquids at elevated temperatures has been in maintaining accurate temperature control that is consistent from sample to sample so that meaningful data could be obtained. The LAMY Thermocell solves this problem by providing a stable, precisely controlled sample environment. This, together with the inherent accuracy of the LAMY Viscometers, is fundamental to the Thermocell System, which produces viscosity measurements that are not only accurate but entirely reproducible.

Several factors contribute to the stable environment:

- ◆ Non-fluctuating temperature control.
- ◆ Small sample volume and insulated sample chamber which reduces temperature gradients within the sample.
- ◆ The rotating spindle, which acts as a built-in stirring device.
- ◆ The test procedure is quite straightforward. Once familiar with the system, unskilled operators can easily produce accurate, reproducible data.



## ACCESSORIES

### CPS (Viscosity Standard Fluids)

LAMI Silicone Viscosity Standards provide a convenient, reliable means of checking the performance of most Viscometers / Rheometers. These fluids are calibrated at 25°C and available in 500mL per standard bottle.



- Specify required viscosity standard when ordering from 11 different viscosity range to choose from 5cP, 10cP, 50cP, 100cP, 500cP, 1000cP, 5000cP, 12,500cP, 30,000cP, 60,000cP, 100,000 cP.

### HeliPRO (For Creams, Gels, Ointments, etc.)

LAMY RHEOLOGY HELIPRO Measuring System designed for Viscosity / Consistency measurements of products such as Gels, Pastes, Creams, Ointments, Putty, Gelatin and other non-flowing substances. HeliPro is supplied complete with Set of 6 x T-Bar Spindles in case, Motorized Stand, Hex Screw Driver, Adaptor for for operation on 220V.



The LAMY HeliPro Package, when used with a suitable Viscometer/Rheometer fitted with a special T-bar type spindle, will permit viscosity/consistency measurements in relative centipoise values for materials having characteristics similar to paste, putty, cream, gelatin, or wax.

Many substances, because of the nature of their yield values, have been considered unsuitable for viscosity or consistency measurements with rotational viscometers. Any rotating spindle, be it cylinder, disc, or paddle, will create a channel in such substances and after a very short time exert a negligible and meaningless torque on any sensing device. This effect also occurs with materials that have a gel structure.

Paint dyes, lithographic inks, and many other substances are thixotropic in that their structure is broken down and their viscosity is decreased when subjected to internal shearing. While no rotating spindle will ever spin freely in such materials, the torque required to produce this motion will become less as the period of internal shearing lengthens. The study of such data can lead to difficulties and require rigid testing procedures for QC. Other materials, notably pastes and creams, show a combination of the two effects listed above. They will show a yield value as well as a change in relative viscosity/consistency with time.

### MS-CP (Cone & Plate Spindles)



LAMY Measuring System MS-CP-AC265 Cone Plate Spindles. This Measuring systems cone or plate compatible with DIN 53019 / ISO 3219 / ASTM D4278-D7395 (316L Stainless Steel). These systems make it possible to set the shear rate in order to carry out viscosity measurements or to obtain curves to study flow behavior, yield stress or thixotropy. They are particularly suitable for measurements on very small quantities for control or development of homogeneous products with or without particles (size <math><100\mu\text{m}</math>), guaranteeing easy cleaning. In addition to these advantages, the AC 265 coupling guarantees quick setup of the measuring system, better maintenance and increased repeatability.



## PORTABLE B-ONE

The B-ONE PORTABLE is the ideal tool for your viscosity measurements in the workshop, production area, delivery area or outside. With one hour of battery life, it will optimize your control times and flexibility.



- ♦ Autonomy more than one hour.
- ♦ Charge indicator.
- ♦ Direct measure with time to stop.
- ♦ Usable with standard or rack stand (option).
- ♦ User and locked mode.
- ♦ Data recording and USB transfer.
- ♦ Torque gage on display.
- ♦ Display of viscosity limits according to mobile and speed.

## PORTABLE RM-100

No matter where, the RM100 PORTABLE allows you to bring your viscosity measurement methods where your lab can not operate. With programming, memorization, temperature measurement and all measuring systems, all your expertise is moving!



- ♦ Autonomy more than one hour.
- ♦ Charge indicator.
- ♦ Huge speed and torque range.
- ♦ Usable with standard or rack stand (option).
- ♦ Programming and recording method.
- ♦ Direct measure with time to stop.
- ♦ User and locked mode.
- ♦ Data recording and USB transfer.
- ♦ Torque gage on display.
- ♦ Integrated temperature probe.
- ♦ Printer connection.
- ♦ Compatible with RheoTex software.
- ♦ Display of viscosity limits according to mobile and speed.

## RM 100 i

The RM100 i is perfectly suited for so-called immersion use, installing it over a tank or on a support for a measurement in a pot. Only the measuring head is above the product, the electronic box can be installed more than 15 meters in a control cabinet with its 4-20mA output.



- ♦ Industrial measure on large tanker.
- ♦ Continuous measurement or with time to stop.
- ♦ 4-20 mA output for external control.
- ♦ 17m maximum distance between head and box.
- ♦ Usable with standard or rack stand.
- ♦ Programming and recording methods.
- ♦ Huge viscosity range.
- ♦ External temperature probe (option).
- ♦ Printer connection.
- ♦ Compatible with RheoTex software.
- ♦ Display of viscosity limits according to mobile and speed.

## RM 100 L

The online viscosity measurement of the RM100 L guarantees continuous control for immediate action in production. Whatever the flow rate, the viscosity or the diameter of your pipe, this viscometer will be able to adapt by guaranteeing you a measurement according to laboratory's norms.



- ♦ Industrial on-line measurement.
- ♦ Continuous measurement or with time to stop.
- ♦ 4-20 mA output for external control.
- ♦ 25m maximum distance between head and box.
- ♦ Magnetic bearing for sealing.
- ♦ Programming and recording methods.
- ♦ Huge viscosity range.
- ♦ External temperature probe (option).
- ♦ Printer connection.
- ♦ Compatible with RheoTex software.
- ♦ Display of viscosity limits according to mobile and speed.





## Other Products

Amkette analytics supports many principals globally and with a Pan-Indian map coverage they serve all customers with any analytical or laboratory needs that may come up as shown by over 20 years of experience.

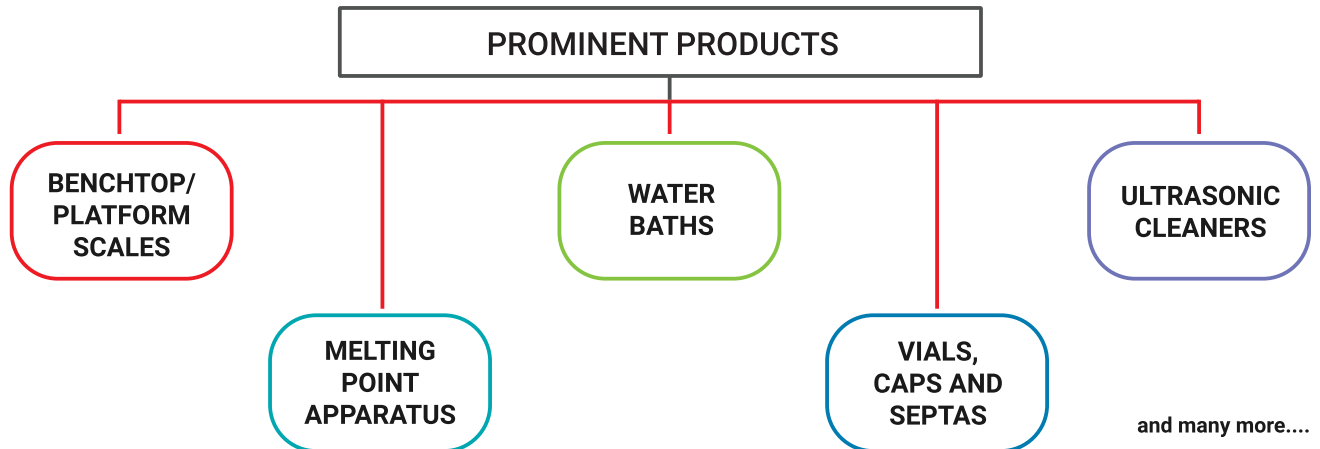

### VARIOUS ADVANTAGES

- **Reference Standard**
  - Certified Reference Materials (CRMs) and Calibration Standards for Analytical Spectroscopy and Chromatography.
- **Water Baths**
  - Quiet, energy efficient heat removal.
  - Cool Command™ - Innovative technology extracts heat quickly and efficiently, ensuring more precise temperature control and stability.
- **Ultrasonic Cleaner**
  - The Most Powerful Bench-top ultrasonic cleaner.
  - Powerful and reliable cleaning.
- **Melting Point Apparatus**
  - Automatic and visual determination.
  - Stand-alone operation and computer control (USB).
- **Precision Electronic Balance**
  - Designed for accuracy.
  - Fast Response.

### APPLICABLE INDUSTRIES

- Automobile Industry
- Chemical Industry
- Electronics Industry
- Pharmaceutical Industry
- Cosmetics Industry
- Aerospace Industry
- Food/Beverage Industry
- Paint & Coatings Industry
- Petroleum Industry
- Hydrocarbon Industry
- Biotech Industry
- Textile Industry
- Environmental Research
- Packaging Industry
- Transport Industry
- Agricultural Industry
- Construction Industry
- Hospitality Industry
- Healthcare Industry





## Melting Point Apparatus - Automated

The pro version of the Meltview 2 software is FDA 21 CFR Part 11 ready. It enables users to integrate the MPA100 into a compliance based lab environment. Both stand alone and client/server modes are available.



- Completely automated operation.
- PID-controlled temperature ramping.
- Digital movie of each melt.
- Stand-alone operation and computer control (USB).
- Conforms to Pharmacopoeia and GLP.
- Printer output.
- Live images during melts.
- Single-click data acquisition with auto-saving to a central database.
- View data from any computer on the network.
- Permission-based operations. User login required on all applications.
- Electronic signatures on collected data.
- Audit trail recording all user activities with messages to discern invalid or altered records.
- Measurement report in PDF. Audit logs export to PDF or CSV.
- Easy user management from any computer on the network.
- Data backup/restore with schedule and recurring option.
- Stored files can be recalled for frame-by-frame playback.

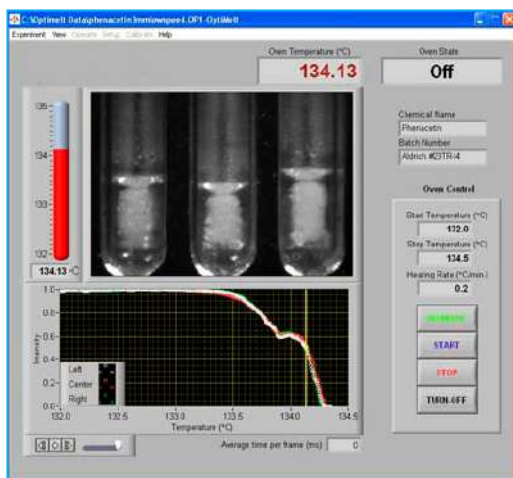

Meniscus Point Software

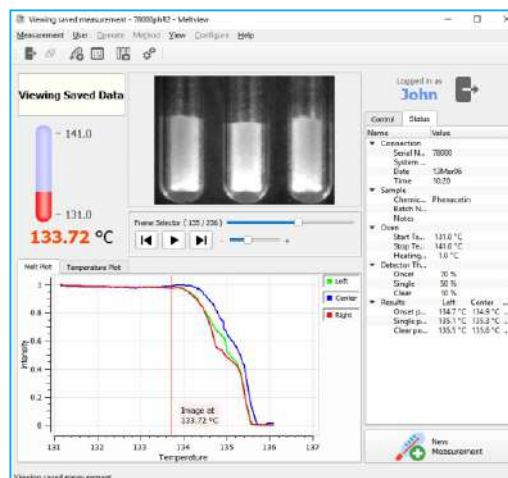

Measurement and Recall



### 9mm Screw Top Vials, Cap and Septa

### 8mm Screw Top Vials, Cap and Septa



### 11mm Snap Top Vials, Cap and Septa

### 11mm Crimp Top Vials, Cap and Septa



### 9mm LC Clean Bonded Screw Cap



**NEW**

- ◆ Color free, Bonded ultra clean septa.
- ◆ For all LC HPLC and LCMS analysis.
- ◆ Suitable for critical samples.

### 9mm Magnetic Screw Cap



**NEW**

- ◆ Designed for instruments using a magnetic sample transport system.
- ◆ Truly Bonded Septa.
- ◆ Secure grip to auto sampler magnets.
- ◆ For liquid injection technique (Temp. upto 130°C).

### Ultra Mass Spec Certified Screw, Cap with Septa (UM4)



**NEW**

- ◆ Extreme low-bleed.
- ◆ Conditioned to level 4 standard.
- ◆ Cleanest in the industry.
- ◆ Pharmaceutical grade.



## 20ml Headspace Vials, Cap and Septa

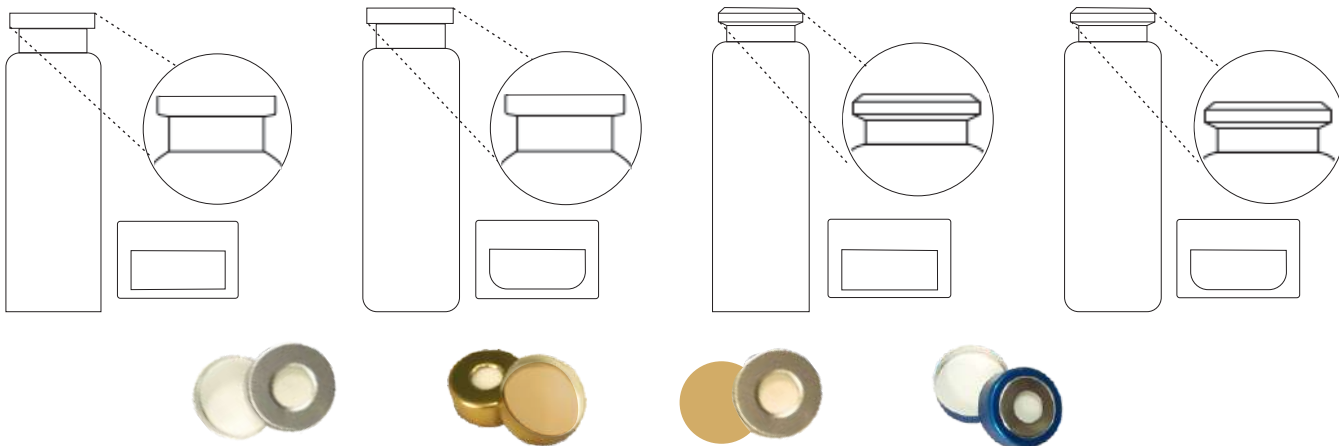

## 20ml Headspace Vials, Cap and Septa



- ◆ No crimping required.
- ◆ Secure grip to autosampler magnets.
- ◆ For Headspace technique.  
(Temp. upto 130°C).

## 18mm PolyMag Screw Cap with SPME MicroCenter Septa



**NEW**

- ◆ Micro thin center.
- ◆ Seals tightly.
- ◆ Easy to pierce.
- ◆ Patented Product.
- ◆ For Headspace technique.  
(Temp. upto 130°C).

## EPA Kit



- ◆ Suitable for water or soil samples.
- ◆ Ultra-low bleed septa are suitable for all environmental sample analysis.
- ◆ Ideal for methods like EPA method 5035.



## Smart Septa (RFID)



- ◆ Scan tags with commercially available RFID handheld devices.
- ◆ Track samples at the individual vial/cap level.
- ◆ Temperature extreme agnostic.
- ◆ Protected from chemical sample with in the silicone/PTFE layers.
- ◆ Tag cannot be removed or tampered with.
- ◆ Customizable data storage parameters.
- ◆ Secure administration of data.

### 1ml Clear Glass Shell Vial with PE Plug Cap 1ml PP Shell Vial with PE Plug Cap



### Manual Decapper 11mm/20mm



### Manual Crimper 11mm/20mm



## D2 Lamp



- ◆ OEM equivalent lamps.
- ◆ Same bare lamps as used to produce.
- ◆ OEM lamp.
- ◆ Guarantee and warranties match those offered by OEM.

## Portable Electronic Balances

Precision without compromise in the field.



- ◆ Designed for accuracy.
- ◆ LCD Display with backlight.
- ◆ Secondary LCD Display Built-in.
- ◆ Acrylic wind Shield included.
- ◆ AC & Battery\* Operations.
- ◆ In-use protective cover.
- ◆ Wide range of capacity, 300g - 10kg.
- ◆ Screw mounted protection for pan support shaft.
- ◆ Economical & affordable price.
- ◆ High Precision.
- ◆ Fast Response.
- ◆ Large pan size.
- ◆ Easy to operate.
- ◆ High Accuracy, 10mg.
- ◆ 1 year warranty.





## Q7 Series Benchtop Scales



- ◆ Touchscreen : 7" TFT Colour Display.
- ◆ PLU Product Management.
- ◆ 128mb RAM, 256mb Flash memory.
- ◆ Capacities : 6kg~30kg.
- ◆ Pan size : 230 x 300mm.
- ◆ 2 x USB high speed; 1 x RS-232 Interface.
- ◆ Housing : ABS plastic.
- ◆ Keyboard : 5keys (Mechanical switch).

## QHW Series Benchtop Scales



- ◆ 24mm LCD, Display with white backlight.
- ◆ Capacities : 3kg~30kg.
- ◆ Platform size : 230 x 300mm.
- ◆ Keyboard : 7keys (Membrane keyboard).
- ◆ Applications: - Check weighing - Counting - Percentage - Accumulation - Weighing unit conversion.
- ◆ Optional RS-232 to connect PC, Printer and ECR.

## S29 Series Waterproof Scales



- ◆ IP65 Water Proof Rating.
- ◆ Optional 20mm rear display.
- ◆ 25mm LCD, Display with white backlight.
- ◆ Capacities : 3kg~25kg.
- ◆ Platform size : 230 x 190mm.
- ◆ Housing : SST.
- ◆ Keyboard : 3keys (Mechanical switch).





## BWS Waterproof Platform Scales



- ◆ Ip65 Water Proof Rating.
- ◆ Stainless steel housing and load cell.
- ◆ Applications: - Check weighing - Accumulation - Animal weighing - Peak hold.
- ◆ 52mm LCD, Display with white backlight.
- ◆ Capacities : 30kg ~ 300kg.
- ◆ Keyboard : 7keys (Mechanical switch).
- ◆ Housing : SST.
- ◆ Optional RS-232 interface to connect to computer or printer.

## BW Series Platform Scales



- ◆ 52mm LCD, Display with white LED backlight.
- ◆ Capacities : 30kg~600kg.
- ◆ Housing : ABS plastic indicator.
- ◆ Keyboard : 7keys (Mechanical switch).
- ◆ Application : - Check weighing - Accumulation - Animal scale - Keyboard lock.
- ◆ Aluminum Diecast Platform & MS Platform Options.
- ◆ Optional RS-232 interface.

## KW Series Platform Scales



- ◆ 24mm LCD, Display with white backlight.
- ◆ Capacities : 30kg ~ 600kg.
- ◆ Keyboard : 7keys (Membrane keyboard).
- ◆ Housing : ABS plastic indicator.
- ◆ Application : - Check weighing - Simply piece counting - Animal scale - Keyboard lock.
- ◆ Optional RS-232 interface can connect to computer or printer.
- ◆ Aluminum Diecast Platform & MS Platform Options.



## Ultrasonic Cleaner

### Powersonic 600 Series



- ◆ Built-in microprocessor controller.
- ◆ High performance industrial BLT type transducer.
- ◆ Selectable use of ultrasonic power (3 steps: Low-1, Medium-2, High-3).
- ◆ Degassing function to eliminate dissolved gas in water or solutions.
- ◆ User-friendly control panel for easy and simple operation.
- ◆ Elegant style and strong durability.
- ◆ Lid to see the inside of the bath.
- ◆ Built-in alarm function for operation stop.
- ◆ Stainless steel tray (optional).



## Temperature Control Solutions

For over 50 years, PolyScience has been the leader in developing innovative, high quality, precise temperature control solutions.



- ◆  $\pm 0.005^{\circ}\text{C}$  Temperature stability.
- ◆ Capacities from 7 to 75 liters.
- ◆ Swivel 180 Rotating Controllers.
- ◆ LidDock Lid Stowing System.
- ◆ DuraTop Chemical Resistant Deck.
- ◆ Large bath openings and easy to clean surfaces.
- ◆ Four controller types with large, intuitive displays and multiple communication options.



## RO - Tap Test Sieve Shaker

The industry standard in test sieve shakers, W.S. Tyler's RO-TAP® has a unique two-dimensional operation: A horizontal, circular motion and a vertical, tapping motion. This special action allows material particles to stratify and "seek" critical openings in the test media. This unit provides the most accurate and consistent particle analysis testing.



- ◆ Testing Applications - **RX-29**: 2" down through 635 mesh (20 micron) ; **RX-30**: 4" down through 500 mesh (25 micron).
- ◆ Requires minimal maintenance.
- ◆ Heavy-duty use.
- ◆ Features 99 minute digital timer/clock, tolerance, 0.1 second.
- ◆ Each unit is test run and serialized prior to shipment.
- ◆ Oscillations per Minute:  $278 \pm 10$ .
- ◆ Oscillations Displacement: 1-1/8" x 7/16".
- ◆ Taps per Minute:  $150 \pm 10$ .





**ANM TEAM**



**ANM DEALER TEAM**



**ANM HOUSE**





**AmketteAnalytics**  
Limited

ANM House, Plot No. A-141, Road No. 23, Wagle  
Industrial Area, Thane (W) 400 604 INDIA

Tel. : 91-22-6614 1500. 6668 1500

Fax : 91-22-6668 1600

Email : [info@anmalliance.com](mailto:info@anmalliance.com)

Url : [www.anmalliance.com](http://www.anmalliance.com)